

LODES

2021 Preview

Lodes, via Pialoi 32,
30020 Marcon (Venezia) Italy
T +39 041 45 69 266
info@lodes.com – lodes.com

Lighting Makers from *Venice* since 1950

1950–2020 In 2020, as the company celebrates its 70th anniversary, Studio Italia Design changes to *Lodes*, to consolidate our commitment to distinctive decorative design.

In 1950 Angelo Tosetto founded a lighting company in Venice, the heart of Italy's glassmaking region. At that time the company produced artistic lamps in Murano glass. In 1985, the brand adopted a more contemporary design-focused approach and in 1997, it officially became Studio Italia Design. Today, as part of a strategic vision led by General Manager Massimiliano Tosetto, the third generation of the Tosetto family, the rebrand to *Lodes* heralds a new era of contemporary design celebrating the company's principles: *Made in Italy* essence, craftsmanship excellence, relationships, research and development, and technological innovation.

Lodes reflects the brand's refreshed approach to manufacturing innovation and contemporary design consolidating the company's commitment to distinctive decorative design, continuous development and experimentation.

Nel 2020, in occasione del 70° anniversario dell'azienda, Studio Italia Design diventa *Lodes*, a suggellare il nostro percorso nel segno di un design di arredo distintivo.

L'azienda veneziana di illuminazione fu fondata nel cuore della regione italiana del vetro da Angelo Tosetto nel 1950. All'epoca l'azienda produceva lampade artistiche in vetro di Murano. Nel 1985 il brand adotta un approccio più contemporaneo e nel 1997 diventa ufficialmente Studio Italia Design. Oggi, nell'ambito di una visione strategica guidata dal Direttore Generale Massimiliano Tosetto e in occasione del 70° anniversario, il rebranding a *Lodes* annuncia una nuova fase di design contemporaneo che celebra i principi dell'azienda: l'essenza *Made in Italy*, l'eccellenza artigianale, le relazioni, la ricerca e sviluppo, l'innovazione tecnologica.

Lodes testimonia il dinamico approccio del brand all'innovazione produttiva e al design contemporaneo e conferma la vocazione dell'azienda al design decorativo distintivo, allo sviluppo continuo e alla sperimentazione.

"We have been studying light, designing for light and with light all these decades. We can say that we learn from light, and I assure you that light always has plenty to teach us. Our family heritage is deeply connected to our territory: which is Venice, the shiny tesserae of mosaics, the reflections of the lagoon, the squares of the Venetian cities, bustling with merchants and energy. In 2020 we celebrate our 70th anniversary and Studio Italia Design becomes *Lodes*."

"Abbiamo studiato la luce, progettato per la luce e con la luce per tutti questi decenni. Si può dire che impariamo dalla luce, e vi assicuro che la luce ha sempre tanto da insegnarci. Il nostro patrimonio familiare è profondamente legato al nostro territorio: che è Venezia, le tessere lucenti dei mosaici, i riflessi della laguna, le piazze delle città venete animate da mercanti ed energia. Nel 2020 festeggiamo il nostro 70° anniversario e Studio Italia Design diventa *Lodes*."

Massimiliano Tosetto, General Manager

Since the early 2000s our company has invited external designers to collaborate with our R&D team. Our laboratory is the place where designers' creative ideas are shaped, where elaborate sketches give life to visions that evolve until they reach the forms we all desire. The encounter of external design perspectives with our solid manufacturing know-how generates fresh and captivating contemporary product narratives.

Fin dai primi anni 2000 la nostra azienda (allora Studio Italia Design) ha invitato designer esterni a collaborare con il nostro team di ricerca e sviluppo. Il nostro laboratorio è il luogo dove le idee creative dei designer prendono forma, dove elaborati schizzi danno vita a visioni che si evolvono fino a raggiungere la forma desiderata. L'incontro di prospettive progettuali esterne con il nostro solido know-how produttivo genera narrazioni di prodotto contemporanee, fresche e accattivanti.



Luca Nichetto

Easy Peasy
► Table lamp
Year 2020

pag. 10

Other products

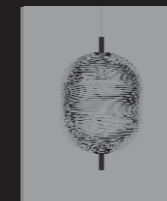

Jefferson
► Suspension lamp

Luca Nichetto founded a multidisciplinary design studio in Venice, Italy, in 2006 which specialised in industrial design, product design and design consulting. From the very beginning, this studio collaborated with a number of different brands and organisations, quickly expanding its influence far beyond Venice and Italy's borders.

Five years later, in 2011, Nichetto opened a second studio in Stockholm, Sweden. This practice was founded in response to an ever-growing number of requests for collaboration from international companies, with the studio's work also broadening out from its initial focus on designed objects.

Nichetto Studio has since expanded into areas such as interior design and architecture. Today, Nichetto Studio works with a variety of brands and clients from all around the world, and its expertise is sought out across all design disciplines.

Nel 2006 *Luca Nichetto* ha fondato a Venezia uno studio di design multidisciplinare dedicato a design industriale, progettazione di prodotto e consulenze. Fin dall'inizio lo studio ha avviato collaborazioni con numerosi brand e organizzazioni, espandendo rapidamente il suo raggio d'azione ben oltre i confini di Venezia e dell'Italia.

Cinque anni più tardi, nel 2011, Nichetto ha aperto un secondo studio a Stoccolma, Svezia. Questo studio nasce in risposta ad un numero sempre maggiore di richieste di collaborazione da parte di aziende internazionali, ampliando il lavoro dello studio anche al di fuori del suo iniziale focus sulla progettazione di oggetti di design.

Nichetto Studio si è ulteriormente ampliato spingendosi in settori affini quali l'interior design e l'architettura. Lo Studio lavora con una varietà di marchi e clienti provenienti da tutto il mondo e la sua esperienza e professionalità sono oggi riconosciute e apprezzate nelle molteplici discipline del mondo del design.



Chia-Ying Lee

Random Solo
► Suspension lamp
Year 2020 pag. 22

Chia-Ying Lee was born in Taiwan and became a designer in new media and industrial. She graduated from the Interaction Design Institute Ivrea in 2006. After working for PEGA Design & Engineering for three years, she set up her studio (studio if) in December 2011. Her work is a blend of design, art and technology embodied in physical forms, from products to installations.

She has worked with important institutes such as the National Taiwan Art Museum and the JUT Foundation for Arts and Architecture. Studio if also runs small production of her works for stores and galleries in Europe, Taipei and Beijing. Her projects have won various awards including “IF China Product Design Award”, “Taiwan Excellence Award” and “SDA Best Design of The Year”. She was selected as one of the IFFS Asian Star Talents in 2015. That same year she designed Random for Studio Italia Design.

Chia-Ying Lee è nata a Taiwan ed è diventata progettista di design industriale e new media. Laureata all'Interaction Design Institute di Ivrea nel 2006, ha lavorato per tre anni per PEGA Design & Engineering, per poi fondare il suo studio (studio if) nel dicembre 2011. Il suo lavoro è una fusione di design, arte e tecnologia incarnata in forme fisiche, dai prodotti alle installazioni.

Ha collaborato con grandi istituti come il National Taiwan Art Museum e la JUT Foundation for Arts and Architecture. Lo studio if realizza anche piccole produzioni delle sue opere per negozi e gallerie in Europa, Taipei e Pechino. I suoi progetti hanno vinto diversi premi tra cui “IF China Product Design Award”, “Taiwan Excellence Award” e “SDA Best Design of The Year”. Nel 2015 è stata selezionata tra i talenti asiatici all'IFFS. Nello stesso anno ha progettato Random per Studio Italia Design.

Other products

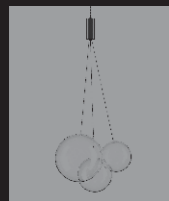

Random
► Suspension lamp

Studio Italia Design



Bugia Mega
► Ceiling lamp
Year 2020

pag. 38

Very often teamwork generates winning ideas. This has been the experience for *Studio Italia Design*, a creative workshop that brings together different intuitions and gives shape to the ideas of the company's own people—technical and creative staff, insiders who know the sector deeply. The results of the synergy of craft, curiosity and speed, contaminated by the endless energy of Andrea Tosetto, are firmly established success stories, like the suspension lamp Sky-Fall, or the A-Tube and Puzzle collections.

Dal lavoro di squadra nascono molto spesso idee vincenti. È questa l'esperienza di *Studio Italia Design*, un laboratorio creativo che accoglie le intuizioni e dà forma alle idee delle persone dell'azienda – tecnici, creativi, conoscitori del settore. I risultati della sinergia di mestiere, curiosità e velocità, contaminati dall'energia inesauribile di Andrea Tosetto, sono storie di successo ormai consolidate, come la lampada a sospensione Sky-Fall e le collezioni A-Tube e Puzzle.

Other products

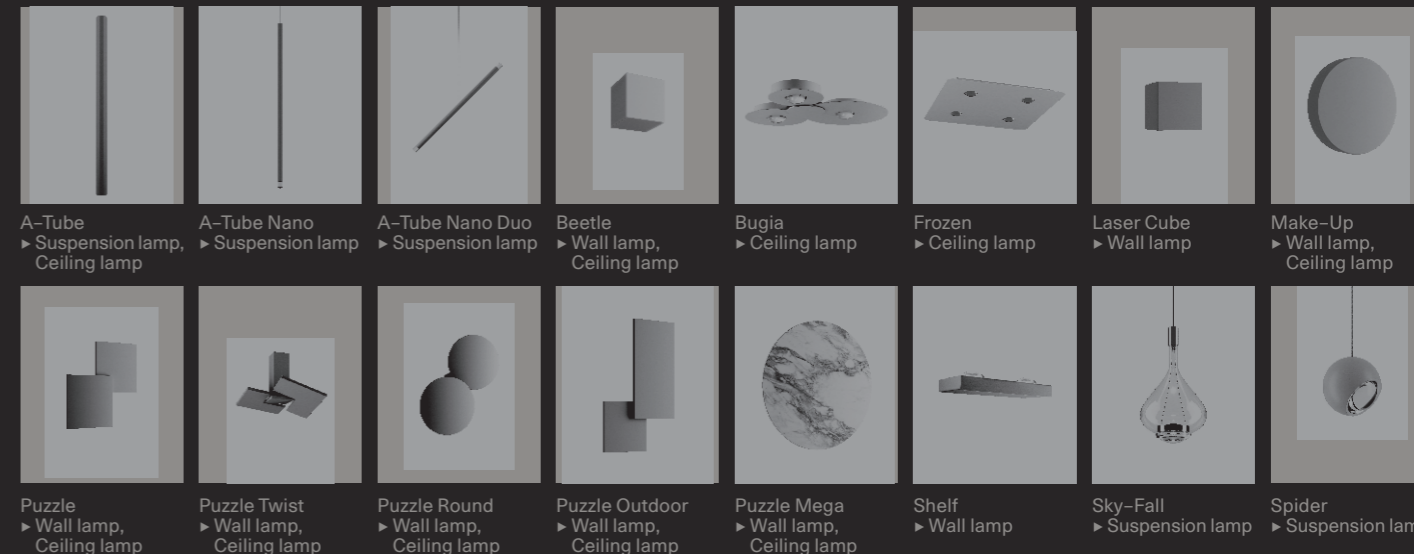

A-Tube
► Suspension lamp, Ceiling lamp

A-Tube Nano
► Suspension lamp

A-Tube Nano Duo
► Suspension lamp

Beetle
► Wall lamp, Ceiling lamp

Bugia
► Ceiling lamp

Frozen
► Ceiling lamp

Laser Cube
► Wall lamp

Make-Up
► Wall lamp, Ceiling lamp

Puzzle
► Wall lamp, Ceiling lamp

Puzzle Twist
► Wall lamp, Ceiling lamp

Puzzle Round
► Wall lamp, Ceiling lamp

Puzzle Outdoor
► Wall lamp, Ceiling lamp

Puzzle Mega
► Wall lamp, Ceiling lamp

Shelf
► Wall lamp

Sky-Fall
► Suspension lamp

Spider
► Suspension lamp



Andrea Tosetto

Kelly Cluster
► Suspension lamp
Year 2015

► NEW FINISH
Matte Champagne

pag. 46

Following his graduation at the Accademia delle Belle Arti in Venice, *Andrea Tosetto* joined the family lighting company, which he soon took over. Andrea marks the transition of the company from the classical lines of that time to an innovative and more contemporary language. His dynamic entrepreneurial style and lively creative vein come to life in refined products that enhance the craftsmanship method. Andrea succeeded in emphasising the company's know-how, focusing on the internalisation of production processes and on the use of quality materials with a strong bond with the Venetian territory. Kelly, Nautilus, and Valentina are just some of Andrea's creations for the company.

Dopo la laurea all'Accademia delle Belle Arti di Venezia, *Andrea Tosetto* entra a far parte dell'azienda di illuminazione fondata dal padre Angelo nel 1950, di cui presto prende le redini. Andrea segna il passaggio dell'azienda dalle linee classiche dell'epoca ad un linguaggio innovativo e più contemporaneo. Il suo stile imprenditoriale dinamico e la sua vena creativa

vivace prendono forma in prodotti curati che esaltano il sistema di lavorazione artigianale. Andrea ha saputo dare protagonismo al saper-fare dell'azienda, mirando all'internalizzazione dei processi di produzione e all'utilizzo di materiali di qualità con un forte legame con il territorio veneziano. Kelly, Nautilus e Valentina sono solo alcune delle creazioni di Andrea per l'azienda.

Other products

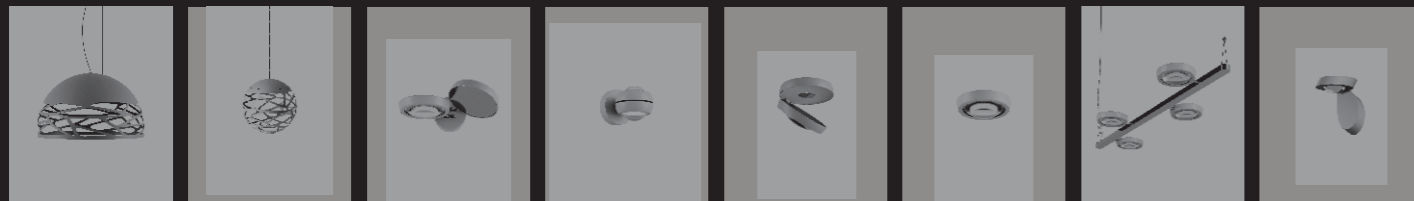

Kelly
► Suspension lamp,
Wall lamp

Kelly Cluster
► Suspension lamp

Nautilus
► Wall lamp

Nautilus Mini
► Wall lamp

Nautilus
► Ceiling lamp

Nautilus Spot
► Ceiling lamp

Nautilus
► Suspension lamp

Pin-Up
► Ceiling lamp,
Wall lamp

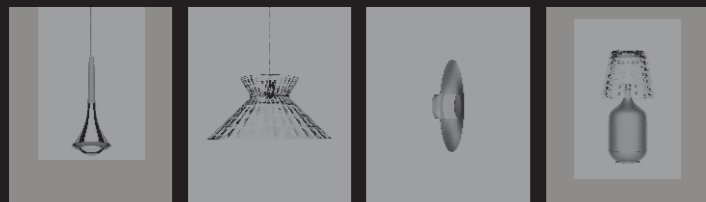

Rain
► Suspension lamp

Sugegasa
► Suspension lamp

Thor
► Ceiling lamp,
Wall lamp

Valentina
► Suspension lamp,
Wall lamp,
Table lamp

Chapter 1–New Concept



Easy Peasy
Table lamp
design by Luca Nichetto
Year 2020

10
spec sheet 21

Chapter 2–Evolution of a Winning Concept



Random Solo
Suspension lamp
design by Chia-Ying Lee
Year 2020

22
spec sheet 35

Chapter 3–Family Extension



Bugia Mega
Ceiling lamp
design by Studio Italia Design
Year 2020

38
spec sheet 44

Chapter 4–New Finish on Metal



Kelly Cluster
Suspension lamp
design by Andrea Tosetto
Year 2015

46
spec sheet 51

New Concept: Easy Peasy

Chapter 1—New Concept: Easy Peasy

Flamingo



Lagoon



Kelp



Chestnut



Easy Peasy

With a sculptural and recognisable form reminiscing the shape of bells, *Easy Peasy* is a set of portable and rechargeable table lamps consisting of two rounded elements, a body and a knob.

Made of blown glass and metal, *Easy Peasy* allows for personal customisation of the living spaces. Its portability, different shapes and colours, and the dim-to-warm functionality of its light source allow users to connect, play and interact with the variable configuration options.

Con una linea sculturale e distintiva che ricorda la forma delle campane, *Easy Peasy* è un set di lampade da tavolo portatili e ricaricabili, composte da due elementi stondati, un corpo e un pomolo.

Realizzata in vetro soffiato e metallo, *Easy Peasy* permette la personalizzazione individuale degli spazi abitativi.

La sua portabilità, le diverse forme e colori, e la funzione dim-to-warm della sua fonte luminosa permettono agli utenti di interagire, giocare e dialogare con le differenti possibilità di configurazione della luce.

Table lamp, lampada da tavolo – Cordless

Easy Peasy family,
Lagoon, Flamingo, Kelp and Chestnut

Easy Peasy, design by Luca Nichetto, 2020





Easy Peasy, body and knob

Easy Peasy,
Chestnut and Kelp



Easy Peasy, turn on and off, dim light intensity and warmth



Easy Peasy, Chestnut and Flamingo





Easy Peasy, lamp portable and rechargeable table

Easy Peasy, design by Luca Nichetto, 2020

Table/Tavolo Cordless

Easy Peasy NEW

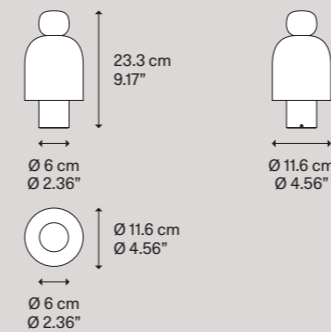

Light source Sorgente luminosa Technopolymer knob Pomolo in tecnopolimero Blown glass shade Cappello in vetro soffiato Metal base Base in metallo Code Codice

Flamingo

LED • Dim-to-warm from 2700 K to 3300 K • 3 W/380 lm • 2000 mA • CRI 90 • MacAdam 3-Step	Pink NEW Rosa	Grey NEW Grigio	Brushed Bronze Spazzolato NEW	170001
---	---------------	-----------------	-------------------------------	--------

Lagoon

LED • Dim-to-warm from 2700 K to 3300 K • 3 W/380 lm • 2000 mA • CRI 90 • MacAdam 3-Step	Turquoise NEW Turchese	Honey NEW Miele	Brushed Gold Oro Spazzolato NEW	170002
---	------------------------	-----------------	---------------------------------	--------

Weight/Peso: 0.85 kg Gross weight/Peso lordo: 1.45 kg Pack/Colli: N°1 Volume: 0.013 m³



Easy Peasy NEW

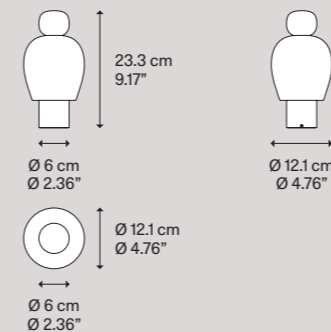

Light source Sorgente luminosa Technopolymer knob Pomolo in tecnopolimero Blown glass shade Cappello in vetro soffiato Metal base Base in metallo Code Codice

Kelp

LED • Dim-to-warm from 2700 K to 3300 K • 3 W/380 lm • 2000 mA • CRI 90 • MacAdam 3-Step	Green NEW Verde	Honey NEW Miele	Brushed Rose Gold Oro Rosa Spazzolato NEW	170003
---	-----------------	-----------------	---	--------

Chestnut

LED • Dim-to-warm from 2700 K to 3300 K • 3 W/380 lm • 2000 mA • CRI 90 • MacAdam 3-Step	Taupe NEW Grigio Caldo	Grey NEW Grigio	Brushed Palladium Palladio Spazzolato NEW	170004
---	------------------------	-----------------	---	--------

Weight/Peso: 0.85 kg Gross weight/Peso lordo: 1.45 kg Pack/Colli: N°1 Volume: 0.013 m³



Battery charging time Tempo di ricarica	Battery life Durata batteria
Power supply 1 A ▶ 180' min	Full power (100%) ▶ 6h Half power (50%) ▶ 10h Minimum power (10%) ▶ 19h

Evolution of a Winning Concept: Random Solo

Chapter 2—Evolution of a Winning Concept: Random Solo



○ Clear/Trasparente

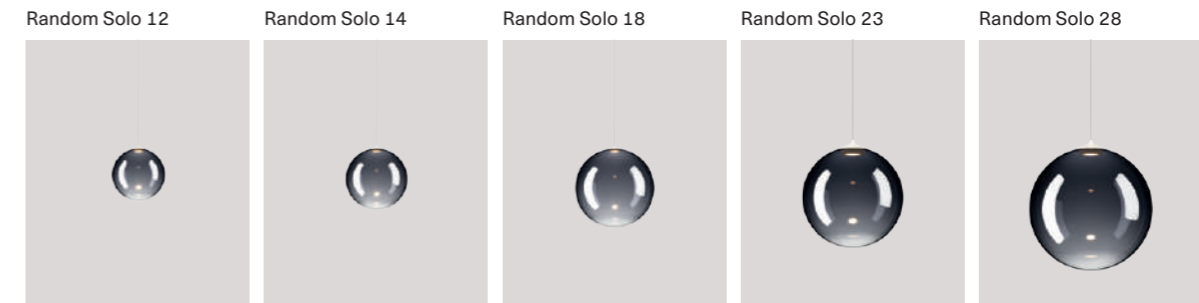

● Glossy Smoke/Fumo Lucido

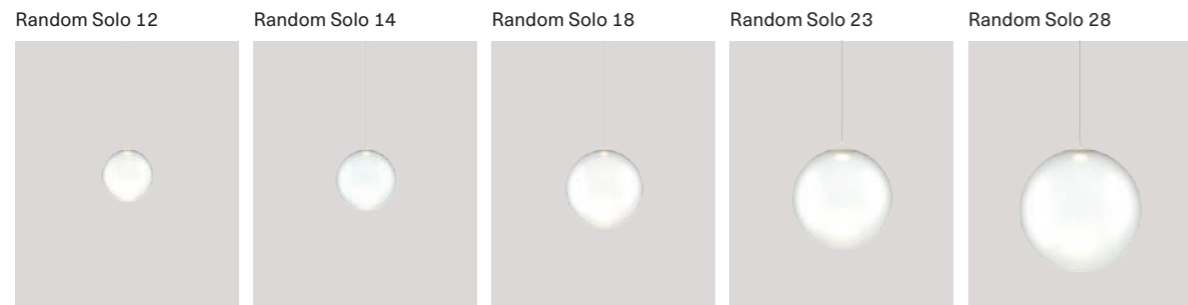

○ Frosted White/Bianco Satinato

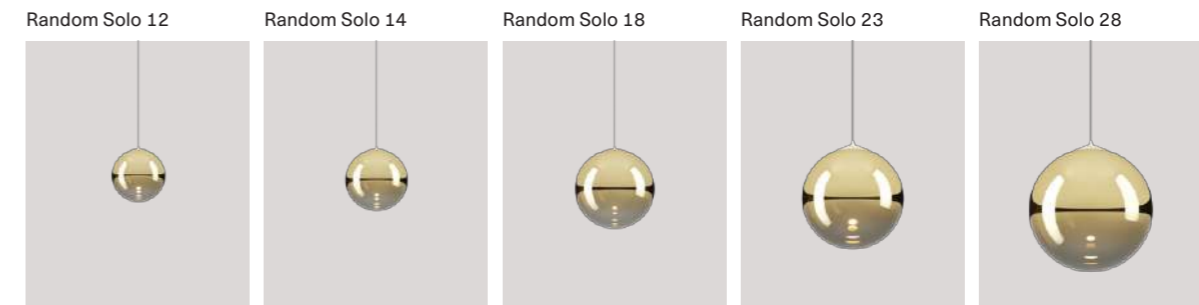

● Gold/Oro

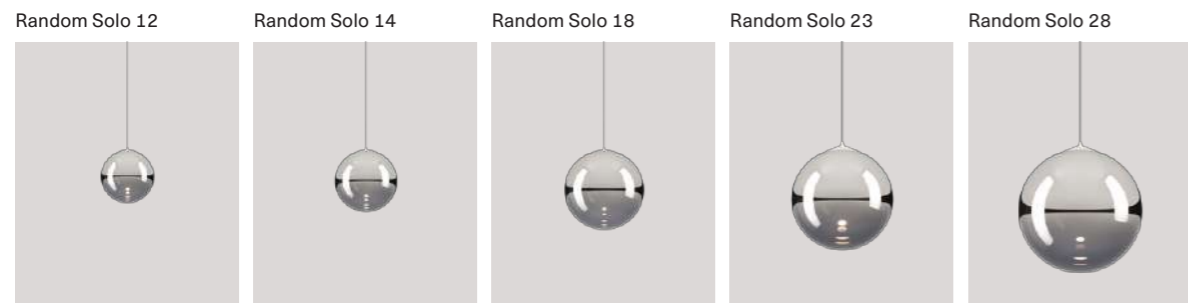

Ⓛ Chrome/Cromo

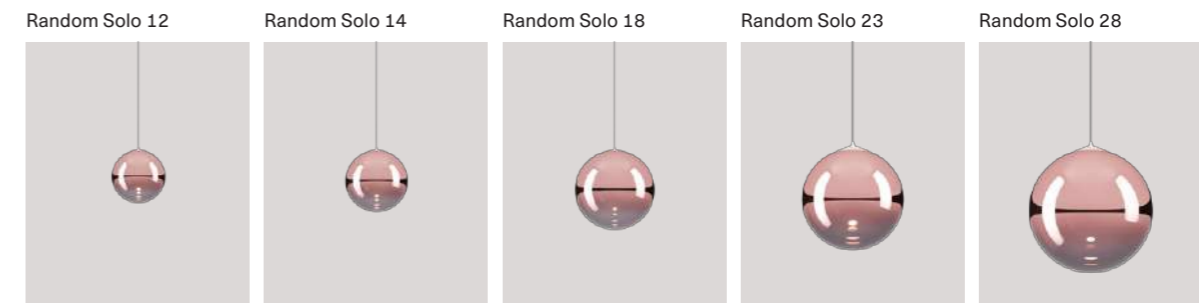

● Rose Gold/Oro Rosa

Random Solo

Perfect spheres floating in the air like gentle glass bubbles, the five diffusers with a diameter of 12, 14, 18, 23 and 28 cm offer ample freedom to compose harmonies of lights, whether in one colour or combining the six different finishes. *Random Solo* progresses the design of the existing *Random* range by isolating the original three-piece cluster and adding two new spherical, blown-glass lamps. Each glass diffuser integrates an LED light source that provides a warm white light.

Sfere perfette che fluttuano nell'aria come delicate bolle di vetro, i cinque diffusori di diametro 12, 14, 18, 23 e 28 cm offrono un'ampia libertà di comporre armonie di luci, sia in un unico colore che combinando le sei diverse finiture. *Random Solo* evolve il design dell'attuale collezione *Random* separando l'originale cluster a tre elementi e aggiungendo due nuove lampade sferiche in vetro soffiato. Su ciascun diffusore in vetro è installata una sorgente luminosa a LED che diffonde una calda luce bianca.

Suspension lamp, lampada a sospensione

Random Solo 18, 23 and 28,
FINISH Frosted White, Glossy Smoke and Clear

Random Solo, *design by Chia-Ying Lee, 2020*





Random Solo 12, 14, 18, 23 and 28,
FINISH Clear and Glossy Smoke

Random Solo 23 and 28,
Round Cluster System, composition of 14 lights,
FINISH Clear and Glossy Smoke



Random Solo 12, 14, 18, 23 and 28,
FINISH Chrome and Clear





Random Solo 23 and 28,
FINISH Clear and Rose Gold

Random Solo 23 and 28,
Round Cluster System, composition of 5 lights
Random Solo 14, FINISH Clear and Rose Gold



Random Solo,
FINISH Frosted White

Random Solo,
FINISH Glossy Smoke and Clear

Random Solo, design by Chia-Ying Lee, 2020

Suspension/Sospensione

Random Solo 12 NEW

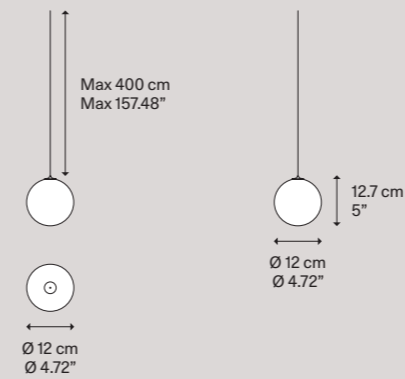

Light source
Sorgente luminosa

LED
• 2700 K
• 1 W/150 lm
• 350 mA
• CRI 90
• MacAdam 3-Step

LED and driver included
LED e driver inclusi

or

LED
• 3000 K
• 1 W/160 lm
• 350 mA
• CRI 90
• MacAdam 3-Step

LED and driver included
LED e driver inclusi

Blown glass diffuser
Diffusore in vetro soffiato

Clear
Trasparente

Frosted White
Bianco Satinato

Chrome
Cromo

Glossy Smoke
Fumo Lucido

Gold
Oro

Rose Gold
Oro Rosa

Clear
Trasparente

Frosted White
Bianco Satinato

Chrome
Cromo

Glossy Smoke
Fumo Lucido

Gold
Oro

Rose Gold
Oro Rosa

Code
Codice

171001

171002

171003

171004

171005

171006

171007

171008

171009

171010

171011

171012

Weight/Peso: 0.25 kg

Gross weight/Peso lordo: 0.35 kg

Pack/Colli: N°2

Volume: 0.006 m³

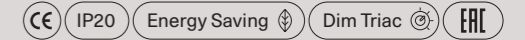

Random Solo 14 NEW

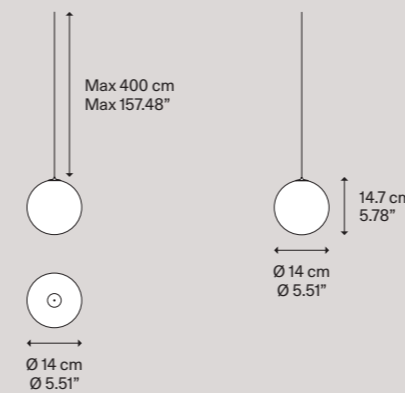

LED
• 2700 K
• 1 W/150 lm
• 350 mA
• CRI 90
• MacAdam 3-Step

LED and driver included
LED e driver inclusi

or

LED
• 3000 K
• 1 W/160 lm
• 350 mA
• CRI 90
• MacAdam 3-Step

LED and driver included
LED e driver inclusi

Clear
Trasparente

Frosted White
Bianco Satinato

Chrome
Cromo

Glossy Smoke
Fumo Lucido

Gold
Oro

Rose Gold
Oro Rosa

Clear
Trasparente

Frosted White
Bianco Satinato

Chrome
Cromo

Glossy Smoke
Fumo Lucido

Gold
Oro

Rose Gold
Oro Rosa

171013

171014

171015

171016

171017

171018

171019

171020

171021

171022

171023

171024

Weight/Peso: 0.32 kg

Gross weight/Peso lordo: 0.44 kg

Pack/Colli: N°2

Volume: 0.009 m³

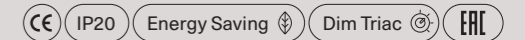

Random Solo, design by Chia-Ying Lee, 2020

Suspension/Sospensione

Random Solo 18 **NEW**

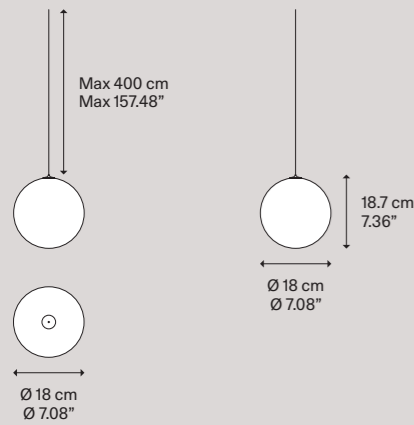

Light source
Sorgente luminosa

LED
• 2700 K
• 1 W/150 lm
• 350 mA
• CRI 90
• MacAdam 3-Step

LED and driver included
LED e driver inclusi

or

LED
• 3000 K
• 1 W/160 lm
• 350 mA
• CRI 90
• MacAdam 3-Step

LED and driver included
LED e driver inclusi

Blown glass diffuser
Diffusore in vetro soffiato

- Clear
Trasparente
- Frosted White
Bianco Satinato
- Chrome
Cromo
- Glossy Smoke
Fumo Lucido
- Gold
Oro
- Rose Gold
Oro Rosa
- Clear
Trasparente
- Frosted White
Bianco Satinato
- Chrome
Cromo
- Glossy Smoke
Fumo Lucido
- Gold
Oro
- Rose Gold
Oro Rosa

Code
Codice

- 171025
- 171026
- 171027
- 171028
- 171029
- 171030
- 171031
- 171032
- 171033
- 171034
- 171035
- 171036

Weight/Peso: 0.8 kg Gross weight/Peso lordo: 0.92 kg Pack/Coll: N°2 Volume: 0.025 m³

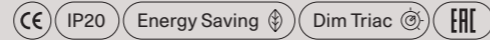

Random Solo, design by Chia-Ying Lee, 2020

Suspension/Sospensione

Random Solo 28 **NEW**

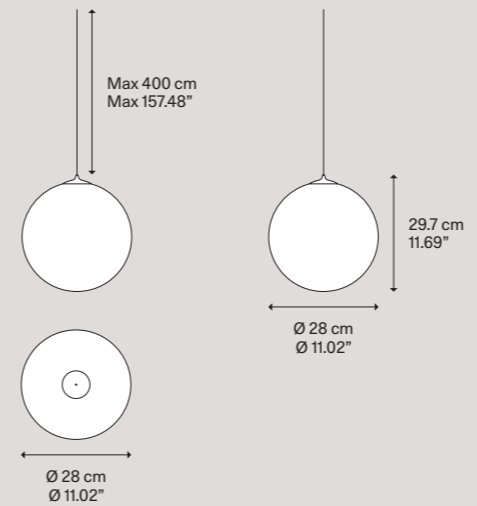

Light source
Sorgente luminosa

LED
• 2700 K
• 3 W/450 lm
• 350 mA
• CRI 90
• MacAdam 3-Step

LED and driver included
LED e driver inclusi

or

LED
• 3000 K
• 3 W/480 lm
• 350 mA
• CRI 90
• MacAdam 3-Step

LED and driver included
LED e driver inclusi

Blown glass diffuser
Diffusore in vetro soffiato

- Clear
Trasparente
- Frosted White
Bianco Satinato
- Chrome
Cromo
- Glossy Smoke
Fumo Lucido
- Gold
Oro
- Rose Gold
Oro Rosa
- Clear
Trasparente
- Frosted White
Bianco Satinato
- Chrome
Cromo
- Glossy Smoke
Fumo Lucido
- Gold
Oro
- Rose Gold
Oro Rosa

Code
Codice

- 171049
- 171050
- 171051
- 171052
- 171053
- 171054
- 171055
- 171056
- 171057
- 171058
- 171059
- 171060

Weight/Peso: 1.8 kg Gross weight/Peso lordo: 2.1 kg Pack/Coll: N°2 Volume: 0.045 m³

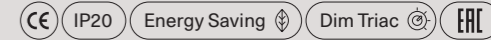

Random Solo 23 **NEW**

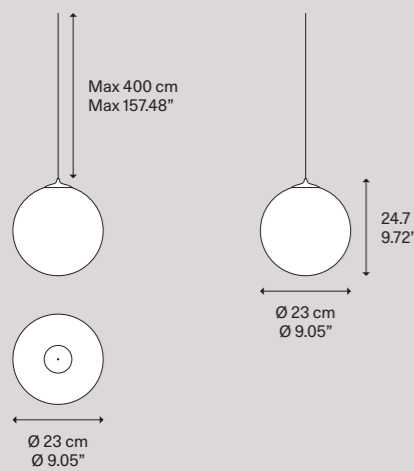

LED
• 2700 K
• 3 W/450 lm
• 350 mA
• CRI 90
• MacAdam 3-Step

LED and driver included
LED e driver inclusi

or

LED
• 3000 K
• 3 W/480 lm
• 350 mA
• CRI 90
• MacAdam 3-Step

LED and driver included
LED e driver inclusi

- Clear
Trasparente
- Frosted White
Bianco Satinato
- Chrome
Cromo
- Glossy Smoke
Fumo Lucido
- Gold
Oro
- Rose Gold
Oro Rosa
- Clear
Trasparente
- Frosted White
Bianco Satinato
- Chrome
Cromo
- Glossy Smoke
Fumo Lucido
- Gold
Oro
- Rose Gold
Oro Rosa

- 171037
- 171038
- 171039
- 171040
- 171041
- 171042
- 171043
- 171044
- 171045
- 171046
- 171047
- 171048

Weight/Peso: 1.1 kg Gross weight/Peso lordo: 1.23 kg Pack/Coll: N°2 Volume: 0.025 m³

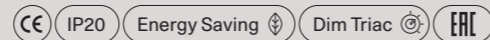

The suspensions must be installed with one of the CANOPY options ► lodes.com/canopies
Le sospensioni devono essere installate sui ROSONI ► lodes.com/canopies

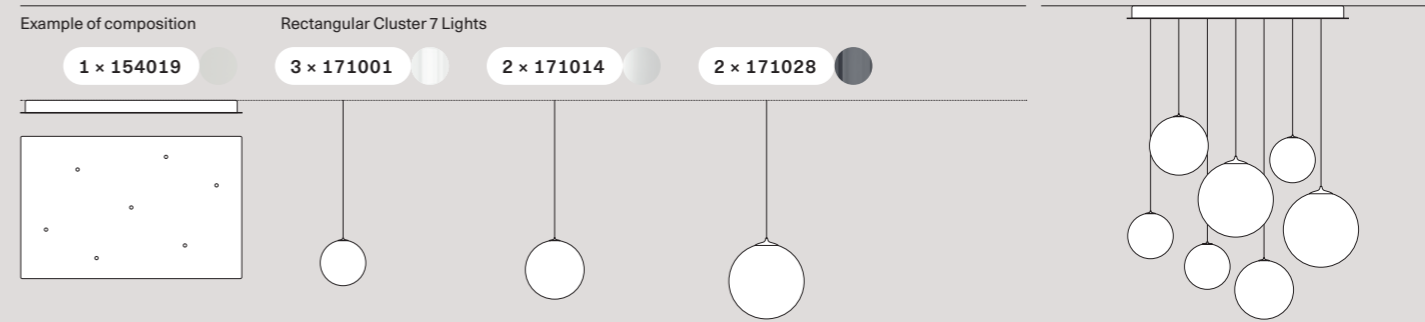

Family Extension: Bugia Mega

Chapter 3-Family Extension: Bugia Mega

Bugia Mega NEW



○ White/Bianco

◐ Chrome/Cromo

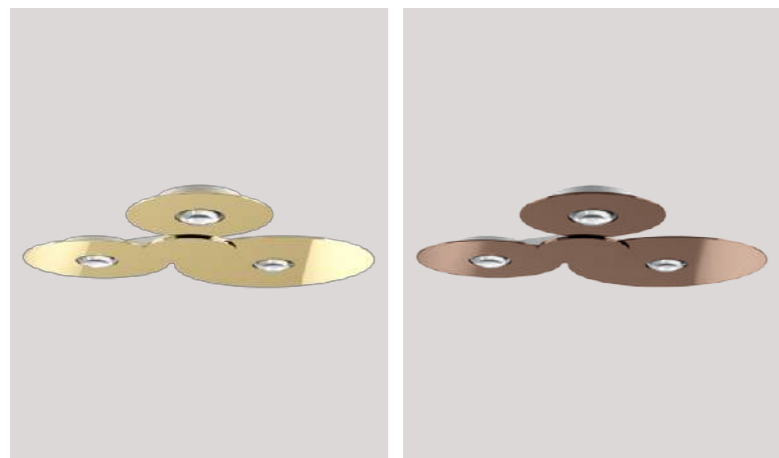

● Gold/Oro

● Glossy Copper/Rame Lucido

Bugia Single

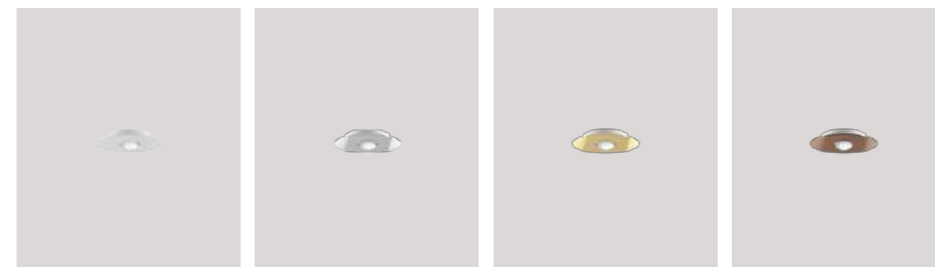

○ White/Bianco

◐ Chrome/Cromo

● Gold/Oro

● Glossy Copper/Rame Lucido

Bugia Double



○ White/Bianco

◐ Chrome/Cromo

● Gold/Oro

● Glossy Copper/Rame Lucido

Bugia Triple



○ White/Bianco

◐ Chrome/Cromo

● Gold/Oro

● Glossy Copper/Rame Lucido

Bugia Mega

Sinuuous shapes with three light sources for a functional ceiling light with an original sign. The new *Bugia Mega* further extends the potential of the Bugia range thanks to its larger shape and its increased lighting power, with the same harmonious balance between direct and indirect light, diffused both downward and up toward the ceiling.

Bugia Mega is suitable for lighting up diverse spaces, perfectly catering to any type of style thanks to the four available finishes: white, gold, chrome and glossy copper.

Forme sinuose con tre fonti di luce per una plafoniera funzionale dal segno originale. La nuova *Bugia Mega* estende ulteriormente il potenziale della gamma Bugia grazie alle forme importanti e alla maggiore potenza illuminante, mantenendo lo stesso equilibrio armonico tra luce diretta e indiretta, diffusa sia verso il basso che verso il soffitto.

Bugia Mega si presta ad illuminare ambienti diversi in perfetta armonia con ogni tipo di stile grazie alle quattro finiture disponibili: bianco, oro, cromo e rame lucido.

Ceiling lamp, lampada da soffitto

Bugia Mega, *design by* Studio Italia Design, 2020



Bugia Mega,
FINISH White



Bugia Single, Double and Triple,
FINISH Glossy Copper

Bugia Mega and Single,
FINISH White

Bugia, design by Studio Italia Design, 2016

Ceiling/Soffitto

Bugia Single

Light source Sorgente luminosa	Metal structure Montatura in metallo	Methacrylate diffuser Diffusore in metacrilato	Code Codice
LED • 2700 K • 15 W/1200 lm • 220-240 V • CRI 90 • MacAdam 3-Step	Matte White - 9010 Bianco Opaco - 9010	White Bianco	161025
		Gold Oro	161026
		Chrome Cromo	161027
LED • 3000 K • 15 W/1275 lm • 220-240 V • CRI 90 • MacAdam 3-Step	Matte White - 9010 Bianco Opaco - 9010	Glossy Copper Rame Lucido	161028
		White Bianco	161029
		Gold Oro	161030
LED • 3000 K • 15 W/1275 lm • 220-240 V • CRI 90 • MacAdam 3-Step	Matte White - 9010 Bianco Opaco - 9010	Chrome Cromo	161031
		Glossy Copper Rame Lucido	161032
LED included LED incluso			

Weight/Peso: 0.8 kg Gross weight/Peso lordo: 1.52 kg Pack/Colli: N°2 Volume: 0.017 m³

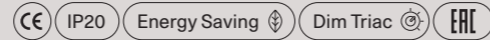

Bugia Double

Light source Sorgente luminosa	Metal structure Montatura in metallo	Methacrylate diffuser Diffusore in metacrilato	Code Codice
LED • 2700 K • 2 x 15 W/2400 lm • 220-240 V • CRI 90 • MacAdam 3-Step	Matte White - 9010 Bianco Opaco - 9010	White Bianco	161033
		Gold Oro	161034
		Chrome Cromo	161035
LED • 3000 K • 2 x 15 W/2550 lm • 220-240 V • CRI 90 • MacAdam 3-Step	Matte White - 9010 Bianco Opaco - 9010	Glossy Copper Rame Lucido	161036
		White Bianco	161037
		Gold Oro	161038
LED • 3000 K • 2 x 15 W/2550 lm • 220-240 V • CRI 90 • MacAdam 3-Step	Matte White - 9010 Bianco Opaco - 9010	Chrome Cromo	161039
		Glossy Copper Rame Lucido	161040
LED included LED incluso			

Weight/Peso: 2.05 kg Gross weight/Peso lordo: 4.91 kg Pack/Colli: N°2 Volume: 0.062 m³

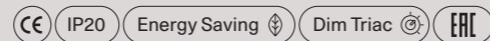

Bugia, design by Studio Italia Design, 2016

Ceiling/Soffitto

Bugia Triple

Light source Sorgente luminosa	Metal structure Montatura in metallo	Methacrylate diffuser Diffusore in metacrilato	Code Codice
LED • 2700 K • 3 x 15 W/3600 lm • 220-240 V • CRI 90 • MacAdam 3-Step	Matte White - 9010 Bianco Opaco - 9010	White Bianco	161041
		Gold Oro	161042
		Chrome Cromo	161043
LED • 3000 K • 3 x 15 W/3825 lm • 220-240 V • CRI 90 • MacAdam 3-Step	Matte White - 9010 Bianco Opaco - 9010	Glossy Copper Rame Lucido	161044
		White Bianco	161045
		Gold Oro	161046
LED • 3000 K • 3 x 15 W/3825 lm • 220-240 V • CRI 90 • MacAdam 3-Step	Matte White - 9010 Bianco Opaco - 9010	Chrome Cromo	161047
		Glossy Copper Rame Lucido	161048
LED included LED incluso			

Weight/Peso: 2.8 kg Gross weight/Peso lordo: 5.66 kg Pack/Colli: N°2 Volume: 0.062 m³

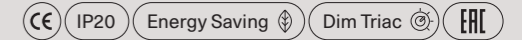

Bugia Mega, design by Studio Italia Design, 2020

Ceiling/Soffitto

Bugia Mega NEW

Light source Sorgente luminosa	Metal structure Montatura in metallo	Methacrylate diffuser Diffusore in metacrilato	Code Codice
LED • 2700 K • 3 x 15 W/3600 lm • 220-240 V • CRI 90 • MacAdam 3-Step	Matte White - 9010 Bianco Opaco - 9010	White Bianco	161049
		Gold Oro	161050
		Chrome Cromo	161051
LED • 3000 K • 3 x 15 W/3825 lm • 220-240 V • CRI 90 • MacAdam 3-Step	Matte White - 9010 Bianco Opaco - 9010	Glossy Copper Rame Lucido	161052
		White Bianco	161053
		Gold Oro	161054
LED • 3000 K • 3 x 15 W/3825 lm • 220-240 V • CRI 90 • MacAdam 3-Step	Matte White - 9010 Bianco Opaco - 9010	Chrome Cromo	161055
		Glossy Copper Rame Lucido	161056
LED included LED incluso			

Weight/Peso: 4.4 kg Gross weight/Peso lordo: 8.8 kg Pack/Colli: N°2 Volume: 0.117 m³

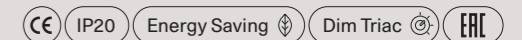

New Finish on Metal: Kelly Cluster

Chapter 4—New Finish on Metal: Kelly Cluster



● Matte Champagne ^{NEW}
/ Champagne Opaco

● Matte Black / Nero Opaco



● Coppery Bronze / Bronzo Ramato

● Matte White / Bianco Opaco

Kelly Cluster

Kelly Cluster is a sculptural and extremely compact sphere which allows the creation of a variety of compositions. A suspension lamp in metal, it features an original and vibrant pattern achieved through precision laser cuts which create an intriguing play of light and shadow. Today Kelly Cluster's high visual impact is enhanced by the new *matte champagne* finish, a refined hue that blends in with a multitude of styles and environments.

Kelly Cluster è una sfera scultorea ed estremamente compatta che permette la creazione di una varietà di composizioni. Lampada a sospensione in metallo, è caratterizzata da un motivo originale e dinamico ottenuto grazie ad una precisa lavorazione a laser che crea un intrigante gioco di luci e ombre. Oggi l'alto impatto visivo di Kelly Cluster è esaltato dalla nuova finitura *champagne opaco*, una tonalità raffinata che si sposa con una moltitudine di stili e ambienti.

Suspension lamp, lampada a sospensione

Kelly Cluster, FINISH Coppery Bronze,
Matte Black and Matte Champagne

Kelly Cluster, *design by* Andrea Toso, 2015





Kelly Cluster, Round Cluster System,
composition of 36 lights, FINISH Matte Champagne

Kelly Cluster, design by Andrea Tosetto, 2015

Suspension/Sospensione

Kelly Cluster

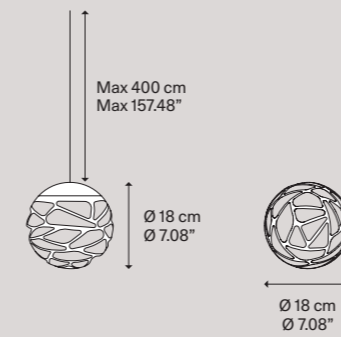

Light source
Sorgente luminosa

LED
• 2700 K
• 9 W / 900 lm
• 220-240 V
• CRI 92
• MacAdam 3-Step

LED and driver included
LED e driver inclusi

Metal structure
Montatura in metallo

Matte White - 9010
Bianco Opaco - 9010
Coppery Bronze
Bronzo Ramato
Matte Black - 9005
Nero Opaco - 9005
Matte Champagne **NEW**
Champagne Opaco

Glass diffuser
Diffusore in vetro

Glossy White
Bianco Lucido

Code
Codice

147013
147014
147015
147016

Weight/Peso: 0.8 kg

Gross weight/Peso lordo: 1.46 kg

Pack/Colli: N°1

Volume: 0.023 m³

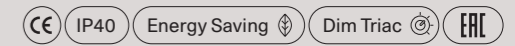

The suspensions must be installed with one of the CANOPY options ▶ lodes.com/canopies
Le sospensioni devono essere installate sui ROSONI ▶ lodes.com/canopies

Example of composition

Round Cluster 3 Lights

1 × 154014

1 × 147014

1 × 147015

1 × 147016

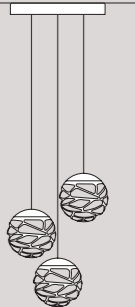
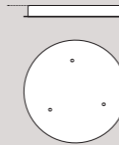

Example of composition

Lights Track Short

1 × 154030

5 × 147016

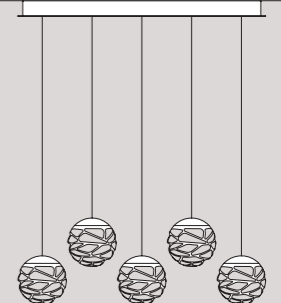
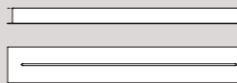

As an integral part of our brand, the colours and finishes of our collections are reminiscent of our territory and of our culture—the architectural elements of Venice, the art of glassblowing, the precious tesserae of mosaics, but also the eccentricities and colourful novelties brought by international traders to Venetian markets. The contemporary tones of our palette enhance Lodes' versatile and eclectic character—sophisticated hues that further boost the potential for living spaces personalisation.

Ingredienti integranti del brand, i colori e le finiture delle collezioni ricordano il nostro territorio e la nostra cultura. Gli elementi architettonici di Venezia, l'arte della soffiatura del vetro, le preziose tessere dei mosaici, ma anche le eccentricità e le colorate novità portate dai mercanti internazionali nelle piazze veneziane. I toni contemporanei della nostra gamma esaltano il carattere versatile ed eclettico di Lodes – tonalità sofisticate che amplificano ulteriormente le spiccate possibilità di personalizzazione degli spazi abitativi.

Foundational/Fondamentali

Precious/Preziosi

Warm/Caldi

Pastels/Pastelli

Trend

Foundational/Fondamentali

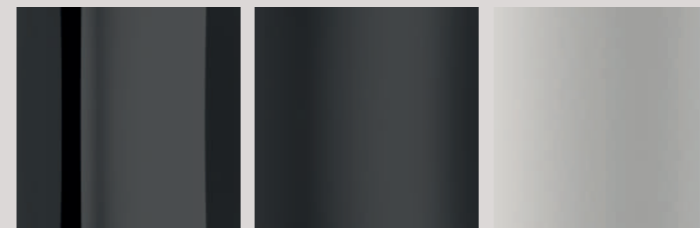

Glossy Black
/Nero Lucido

Matte Black
/Nero Opaco

Grey NEW
/Grigio

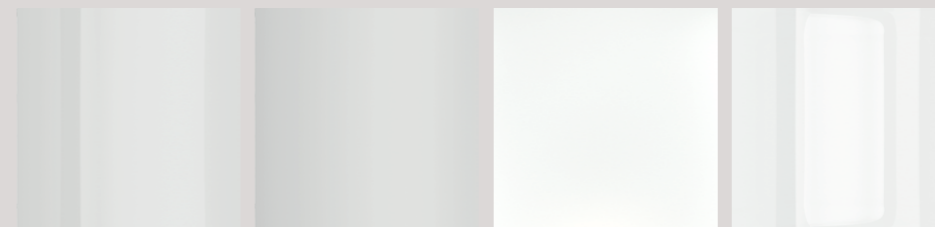

Polished White
/Bianco Lucido

Matte White
/Bianco Opaco

Frosted White NEW
/Bianco Satinato

Clear
/Trasparente

Precious/Preziosi

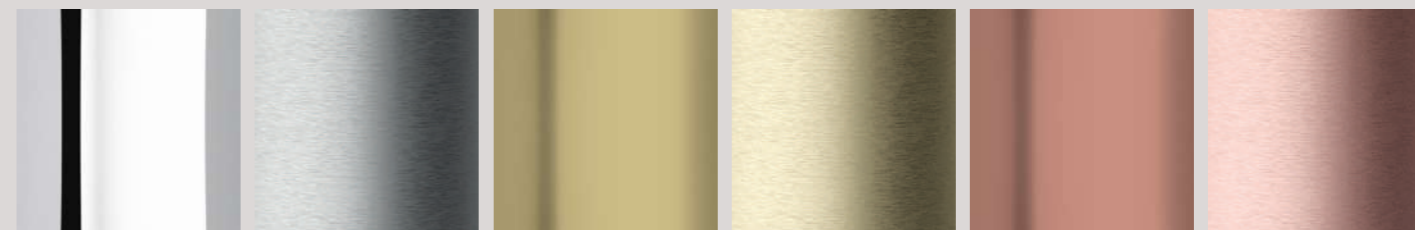

Chrome
/Cromo

Brushed Palladium NEW
/Palladio Spazzolato

Gold
/Oro

Brushed Gold NEW
/Oro Spazzolato

Rose Gold
/Oro Rosa

Brushed Rose Gold NEW
/Oro Rosa Spazzolato

Warm/Caldi

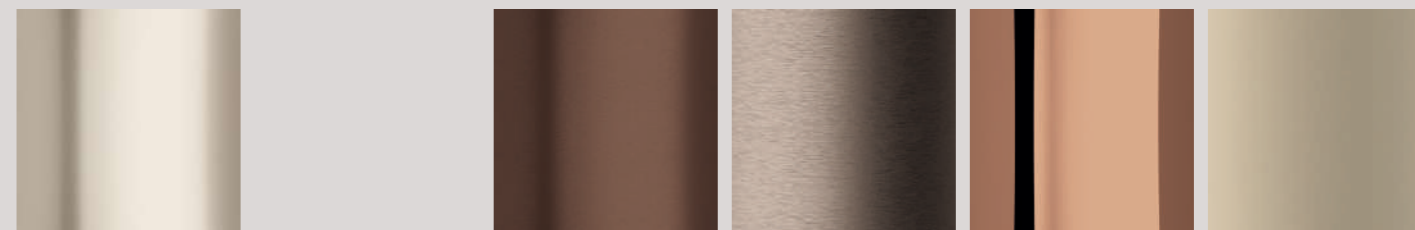

Matte Champagne
/Champagne Opaco

Coppery Bronze
/Bronzo Ramato

Brushed Bronze NEW
/Bronzo Spazzolato

Glossy Copper
/Rame Lucido

Honey NEW
/Miele

Pastels/Pastelli

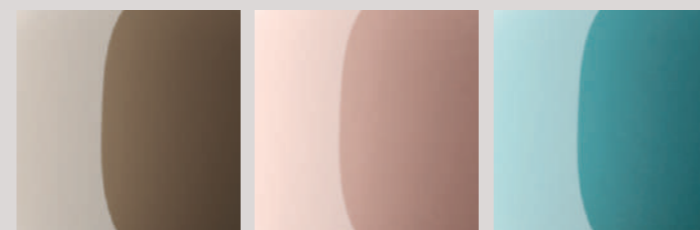

Taupe NEW
/Grigio Caldo

Pink NEW
/Rosa

Turquoise NEW
/Turchese

Trend

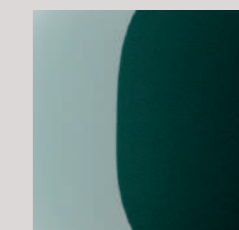

Green NEW
/Verde

Balancing technical know-how and the best *Made in Italy* design, Venice-based *Lodes* has been designing and producing lighting solutions for interiors and exteriors since 1950. Originating in founder Angelo Tosetto's passion for glass and informed by continuous technological research, the company has evolved into one of Europe's leading designers and manufacturers of decorative lighting, currently present in 90 markets worldwide. Today, *Lodes* represents a three-generation evolution from pure passion to brilliant architectural solutions, creating light sources that fuse contemporary design and innovative technology with materials of the highest quality, scrupulously developed with the best processing techniques.

Coniugando il know-how tecnico con il miglior design *Made in Italy*, l'azienda veneziana *Lodes* progetta e produce soluzioni illuminotecniche d'arredo d'interni ed esterni dal 1950. Nata dalla passione per il vetro del fondatore Angelo Tosetto, e guidata dalla costante ricerca tecnologica, l'azienda si è trasformata in uno dei principali designer e produttori europei di illuminazione decorativa, attualmente attiva in 90 mercati nel mondo. Oggi *Lodes* rappresenta un percorso evolutivo, attraverso tre generazioni, dalla pura passione alle più sorprendenti soluzioni architettoniche, grazie a sorgenti luminose in cui design contemporaneo e tecnologia di punta si integrano con materiali di altissima qualità, sapientemente sviluppati con le migliori tecniche di lavorazione.

Lodes, via Pialoi 32,
30020 Marcon (Venezia) Italy
T +39 041 45 69 266
info@lodes.com – lodes.com

2021 Preview

*Art direction
and graphic design*
Think Work Observe
Images
Bruger Studio
Copywritings
Lodes
*Color separation
and printing*
Grafiche Tintoretto

2021 Preview lodes.com

New Concept Easy Peasy *design by* Luca Nichetto, Evolution of a Winning Concept
Random Solo *design by* Chia-Ying Lee, Family Extension Bugia Mega *design by* Studio
Italia Design, New Finish on Metal Kelly Cluster *design by* Andrea Tosetto.