

midas

# podłoga bamboo click H10

Floor BAMBOO CLICK H10  
Пол BAMBOO CLICK H10  
Parkett BAMBOO CLICK H10

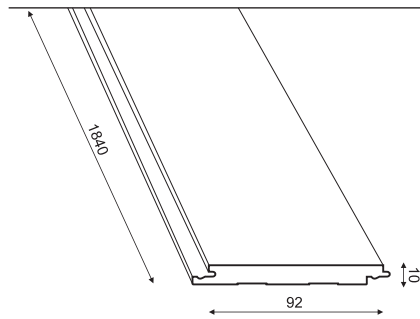

**A-BAM10**

kpl.  
Set  
компл.  
Set

**2,37 m<sup>2</sup>**

**R0, R1, S0**

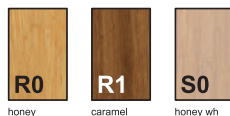

**R0**

honey

**R1**

caramel

**S0**

honey wh

nr artykułu  
article number  
артикул №  
Artikelnummer

j.m.  
unit  
ед.изм.  
Einheit

ilość w opak.  
units / package  
кол. в утпак.  
Stück / VE

nr koloru  
colour number  
цвет №  
Farbnummer



# listwa cokołowa bambusowa

Bamboo skirting boards  
Плинтусы  
Sockelleisten

nr artykułu article number артикул № Artikelnummer	dl. (cm) length (cm) длина (см) Länge (cm)	j.m. unit e. m. Einheit	ilość w opak. units / package кол. в упак. Stück / VE	nr koloru colour number цвет № Farbnummer
A-B5LCO	185	szt. pcs шт. Stück	10	R0, R1, S0

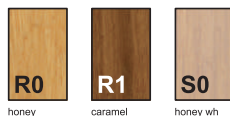
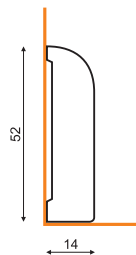

# listwa cokołowa

**aspro®**

Skirting boards  
Плинтусы  
Sockelleisten

aluminium  
алюминиевый  
Alu

	nr artykułu article number артикул № Artikelnummer	dl. (cm) length (cm) длина (cm) Länge (cm)	j.m. unit e.k. Einheit	ilość w opak. units / package кол. в упрк. Stück / VE	nr koloru colour number цвет № Farbnummer
	<b>A-ALU70</b>	<b>240</b>	<b>szt. pcs шт. Stück</b>	<b>1</b>	<b>01</b>
		<b>250</b>	<b>szt. pcs шт. Stück</b>	<b>1</b>	<b>04</b>
	<b>A-A7NW0</b>		<b>szt. pcs шт. Stück</b>	<b>1</b>	<b>A1, A4</b>  <b>Zestaw akcesoriów z aluminium</b>
	<b>A-A7NZ0</b>		<b>szt. pcs шт. Stück</b>	<b>1</b>	
	<b>A-A7ZL0</b>		<b>szt. pcs шт. Stück</b>	<b>1</b>	
	<b>A-A7ZR0</b>		<b>szt. pcs шт. Stück</b>	<b>1</b>	
	<b>A-A7LA0</b>		<b>szt. pcs шт. Stück</b>	<b>1</b>	
	<b>A-AL100</b>	<b>240</b>	<b>szt. pcs шт. Stück</b>	<b>1</b>	<b>01</b>
		<b>250</b>	<b>szt. pcs шт. Stück</b>	<b>1</b>	<b>01</b>
	<b>A-ALU44</b>	<b>250</b>	<b>szt. pcs шт. Stück</b>	<b>1</b>	<b>01, 04</b>



srebrny  
silver  
серебряный  
Silber



szampański  
champagne  
шампанский  
Champagner



srebrny  
silver  
серебряный  
Silber



szampański  
champagne  
шампанский  
Champagner











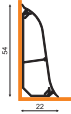

listwa  
cokołowa

aspro®  
2015

Skirting boards  
Плинтусы  
Sockelleisten

aluminium  
алюминиевый  
Alu

	nr artykułu article number артикул № Artikelnummer	dl. (cm) length (cm) длина (см) Länge (cm)	j.m. unit с.и. Einheit	ilość w opak. units / package кол. в ыпак. Stück / VE	nr koloru colour number цвет № Farbnummer
	<b>A-5ZLCO</b>	<b>250</b>	szk. pcs шт. Stück	<b>24</b>	
	<b>A-5ZNW0</b>		szk. pcs шт. Stück	<b>40</b>	
	<b>A-5ZNW1</b>		kpl. (2 szk.) set (2 pcs) компл.(2 шт.) Set (2 Stück)	<b>10</b>	
	<b>A-5ZNZ0</b>		szk. pcs шт. Stück	<b>40</b>	
	<b>A-5ZNZ1</b>		kpl. (2 szk.) set (2 pcs) компл.(2 шт.) Set (2 Stück)	<b>10</b>	<b>A0, A1</b>
	<b>A-5ZZL0</b>		szk. (prawe) pcs (right) шт. (правое) Stück (Rechts)	<b>40</b>	
	<b>A-5ZZR0</b>		szk. (lewe) pcs (left) шт. (левое) Stück (Links)	<b>40</b>	
	<b>A-5ZZK0</b>		kpl.(lewe + prawe) set (left + right) компл.(левое + правое) Set (Links + Rechts)	<b>20</b>	
	<b>A-5ZLA0</b>		szk. pcs шт. Stück	<b>20</b>	
	<b>A-5ZLA1</b>		kpl. (2 szk.) set (2 pcs) компл.(2 шт.) Set (2 Stück)	<b>8</b>	
	<b>A-BFC01</b>		kpl. (24 szk.) set (24 pcs) компл.(24 шт.) Set (24 Stück)	<b>8</b>	
	<b>A-BFC02</b>		kpl. (24 szk.) set (24 pcs) компл.(24 шт.) Set (24 Stück)	<b>8</b>	
	<b>A-TKM01</b>		kpl. (24 szk.) set (24 pcs) компл.(24 шт.) Set (24 Stück)	<b>10</b>	



Silver  
Silver  
Silver  
Silver



Inox  
Inox  
Inox  
Inox











**listwa**  
sokołowa

prexa<sup>®</sup> 54

Skirting boards  
Плитусы  
Sockelleisten

tampondruk

	nr artykułu article number артикул № Artikelnummer	dl. (cm) length (cm) длина (см) Länge (cm)	j.m. unit с.и. Einheit	ilość w opak. units / package кол. в унак. Stück / VE	nr koloru colour number цвет № Farbnummer
	<b>A-PLCOX</b>	<b>250</b>	<b>szt. pcs шт. Stück</b>	<b>28</b>	
	<b>A-PNWE0</b>		<b>szt. pcs шт. Stück</b>	<b>40</b>	<b>F0, F1, F3, F5, F6 F7, F9 G0, G2, G3, G6, G8 H4, H5, H6, H7, H9, K4, K5, K6, K7, K9, W0, 61, W1, W4 W5, L6, L7, L9</b>
	<b>A-PNWE1</b>		<b>kpl. (2 szt.) set (2 pcs) компл. (2 шт.) Set (2 Stück)</b>	<b>10</b>	
	<b>A-PNZW0</b>		<b>szt. pcs шт. Stück</b>	<b>40</b>	
	<b>A-PNZW1</b>		<b>kpl. (2 szt.) set (2 pcs) компл. (2 шт.) Set (2 Stück)</b>	<b>10</b>	
	<b>A-PZAK0</b>		<b>kpl. (lewe + prawe) set (left + right) компл. (левое + правое) Set (Links + Rechts)</b>	<b>20</b>	
	<b>A-PLAC1</b>		<b>kpl. (2 szt.) set (2 pcs) компл. (2 шт.) Set (2 Stück)</b>	<b>20</b>	
	<b>A-BFC01</b>		<b>kpl. (24 szt.) set (24 pcs) компл. (24 шт.) Set (24 Stück)</b>	<b>8</b>	
	<b>A-BFC02</b>		<b>kpl. (24 szt.) set (24 pcs) компл. (24 шт.) Set (24 Stück)</b>	<b>8</b>	
	<b>A-TKM01</b>		<b>kpl. (24 szt.) set (24 pcs) компл. (24 шт.) Set (24 Stück)</b>	<b>10</b>	

<b>F0</b> buk n1 beech n1 Бук n1 Buche n1	<b>F1</b> buk n2 beech n2 Бук n2 Buche n2	<b>F3</b> dab n2 oak n2 Eiche n2	<b>F5</b> kasztan n1 chestnut n1 каштан n1 Kastanie n1	<b>F6</b> wiaz n1 elm n1 вяз n1 Ulme n1	<b>F7</b> orzecz n1 walnut n1 орех n1 Walnuss n1	<b>F9</b> pinia n1 pine n1 Пайн n1 Pinie n1	<b>G0</b> dab n3 oak n3 Eiche n3	<b>G2</b> wenge n1 wenge n1 венге n1 Wenge n1	<b>G3</b> dab n4 oak n4 дуб n4 Eiche n4	<b>G6</b> klon n1 maple n1 клен n1 Ahorn n1	<b>G8</b> dab n6 oak n6 дуб n6 Eiche n6
<b>H4</b> dab n7 oak n7 дуб n7 Eiche n7	<b>H5</b> orzecz n3 walnut n3 орех n3 Walnuss n3	<b>H6</b> dab n11 oak n11 дуб n11 Eiche n11	<b>H7</b> dab n12 oak n12 дуб n12 Eiche n12	<b>H9</b> jabłko n2 apple n2 яблоко n2 Apfelbaum n2	<b>K4</b> dab n10 oak n10 дуб n10 Eiche n10	<b>K5</b> dab oak дуб Eiche	<b>K6</b> dab oak дуб Eiche	<b>K7</b> dab oak дуб Eiche	<b>K9</b> dab grafit graphite oak графит дуб Graphit Eiche	<b>W0</b> dab jasny light oak светлый дуб Eiche hell	<b>61</b> metallic 7 metallic 7 металлик 7 Metallisch 7
<b>W1</b> dab szary серый дуб grey oak Eiche Grau	<b>W4</b> dab oak дуб Eiche	<b>W5</b> dab oak дуб Eiche	<b>L6</b> dab oak дуб Eiche	<b>L7</b> dab oak дуб Eiche	<b>L9</b> dab oak дуб Eiche						







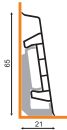

# listwa sokołowa

# Q65

Skirting boards  
Плинтусы  
Sockelleisten



tampondruk

	nr artykułu article number артикул № Artikelnummer	dl. (cm) length (cm) длина (cm) Länge (cm)	j.m. unit е.и. ME	ilość w opak. units / package коп. в улак. Stück / VPE	nr koloru colour number цвет № Farbnummer
	<b>A-L6KOM</b>	<b>250</b>	<b>szt. pcs шт. Stück</b>	<b>24</b>	<b>F6, F9, K7, 6T, W4, 55, W2</b>
	<b>A-L6LC1</b>		<b>kpl. (2 szt.) set (2 pcs) компл. (2 шт.) Set (2 Stück)</b>	<b>10</b>	
	<b>A-L6NW1</b>		<b>kpl. (2 szt.) set (2 pcs) компл. (2 шт.) Set (2 Stück)</b>	<b>4</b>	
	<b>A-L6NZ1</b>		<b>kpl. (2 szt.) set (2 pcs) компл. (2 шт.) Set (2 Stück)</b>	<b>4</b>	
	<b>A-L6ZK1</b>		<b>kpl. (lewe + prawe) set (left + right) компл. (левый + правый) Set (Links + Rechts)</b>	<b>10</b>	
	<b>A-ASQ65</b>		<b>kpl. (5 szt.) set (5 pcs) компл. (5 шт.) Set (5 Stück)</b>	<b>15</b>	
	<b>A-BFC01</b>		<b>kpl. (24 szt.) set (24 pcs) компл. (24 шт.) Set (24 Stück)</b>	<b>8</b>	
	<b>A-BFC02</b>		<b>kpl. (24 szt.) set (24 pcs) компл. (24 шт.) Set (24 Stück)</b>	<b>8</b>	



**F6**

wiąz  
elm  
es3  
Ulme



**F9**

pinia  
oak  
nieven  
Pinie



**K7**

dąb  
oak  
дуб  
Eiche



**6T**

dąb  
oak  
дуб  
Eiche



**W4**

dąb  
oak  
дуб  
Eiche



**55**

metallic 1  
metallic 1  
металлик 1  
Metallisch 1



**W2**

biały  
white  
Белый  
Weiß



# listwa sokołowa

prexa  
next

Skirting boards  
Плинтусы  
Sockelleisten

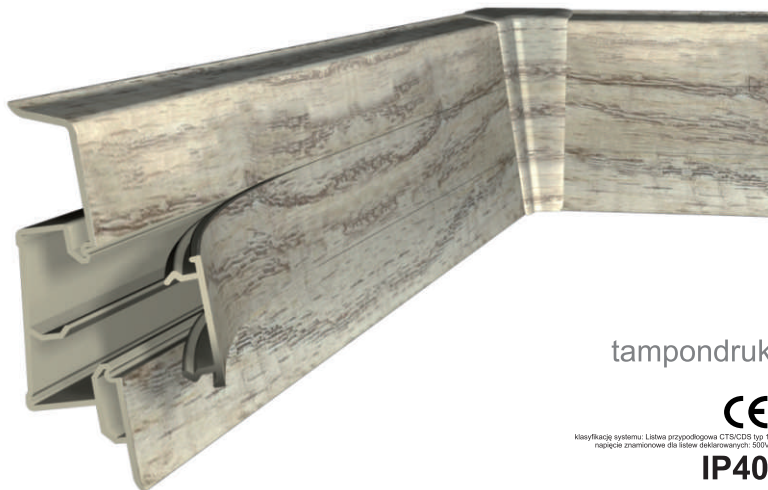

tampondruk



Klasyfikacja systemu: Listwa przypodłogowa CTS/CDS typ 1  
rozcięcie zmienione dla listew deklarowanych: 500V

IP40

	nr artykułu article number артикул № Artikelnummer	dl. (cm) length (cm) длина (см) Länge (cm)	j.m. unit е.и. ME	ilość w opak. units / package коп. в уклад. Stück / VPE	nr koloru colour number цвет № Farbnummer
	<b>A-LCNXT</b>	<b>250</b>	<b>szt. pcs шт. Stück</b>	<b>24</b>	<b>F6, F9, K7, 6T, 3F, L6, W0, V0, V1, V2, V3, V4, V5, V6</b>
	<b>A-L6LC1</b>		<b>kpl. (2 szt.) set (2 pcs) компл. (2 шт.) Set (2 Stück)</b>	<b>10</b>	<b>F6, F9, K7, 6T</b>
	<b>A-LKNXT</b>		<b>kpl. (2 szt.) set (2 pcs) компл. (2 шт.) Set (2 Stück)</b>	<b>10</b>	<b>3F, L6, W0, V0, V1, V2, V3, V4, V5, V6</b>
	<b>A-L6NW1</b>		<b>kpl. (2 szt.) set (2 pcs) компл. (2 шт.) Set (2 Stück)</b>	<b>4</b>	<b>F6, F9, K7, 6T</b>
	<b>A-NWNXT</b>		<b>kpl. (2 szt.) set (2 pcs) компл. (2 шт.) Set (2 Stück)</b>	<b>4</b>	<b>3F, L6, W0, V0, V1, V2, V3, V4, V5, V6</b>
	<b>A-L6NZ1</b>		<b>kpl. (2 szt.) set (2 pcs) компл. (2 шт.) Set (2 Stück)</b>	<b>4</b>	<b>F6, F9, K7, 6T</b>
	<b>A-NZNXT</b>		<b>kpl. (2 szt.) set (2 pcs) компл. (2 шт.) Set (2 Stück)</b>	<b>4</b>	<b>3F, L6, W0, V0, V1, V2, V3, V4, V5, V6</b>
	<b>A-L6ZK1</b>		<b>kpl. (2 szt.) set (2 pcs) компл. (2 шт.) Set (2 Stück)</b>	<b>4</b>	<b>F6, F9, K7, 6T</b>
	<b>A-ZKNXT</b>		<b>kpl. (lewa + prawa) set (left + right) компл. (левый + правый) Set (Links + Rechts)</b>	<b>10</b>	<b>F6, F9, K7, 6T</b>
	<b>A-BFC01</b>		<b>kpl. (24 szt.) set (24 pcs) компл. (24 шт.) Set (24 Stück)</b>	<b>8</b>	<b>3F, L6, W0, V0, V1, V2, V3, V4, V5, V6</b>
	<b>A-BFC02</b>		<b>kpl. (24 szt.) set (24 pcs) компл. (24 шт.) Set (24 Stück)</b>	<b>8</b>	<b>3F, L6, W0, V0, V1, V2, V3, V4, V5, V6</b>



**F6**

wiąz  
elm  
esx  
Ulm



**F9**

pinia  
pine  
пихта  
Pinie



**K7**

dąb  
oak  
дуб  
Eiche



**6T**

dąb  
oak  
дуб  
Eiche



**3F**

dąb  
oak  
дуб  
Eiche



**L6**

dąb biały  
oak white  
дуб белый  
Weiß Eiche



**W0**

dąb jasny  
light oak  
светлый дуб  
Helle Eiche



**V0**

daglezią bielona  
bleached  
Douglas' fir  
беленая пихта  
Дугласа  
geweißte  
Douglasse



**V1**

olcha Oregon  
Oregon alder  
ольха Oregon  
Oregon Erle



**V2**

dąb perłowy  
pearl oak  
жемчужный дуб  
Perle Eiche



**V3**

sosna vintage  
vintage pine  
винтажная сосна  
Vintage Kiefer



**V4**

dąb  
oak  
дуб  
Eiche



**V5**

dąb Baleary  
Baleary oak  
Балеарский дуб  
Baleary Eiche



**V6**

dąb Congo  
Congo oak  
дуб Конго  
Kongo Eiche

# listwa sokołowa



Skirting boards  
Плинтусы  
Sockelleisten

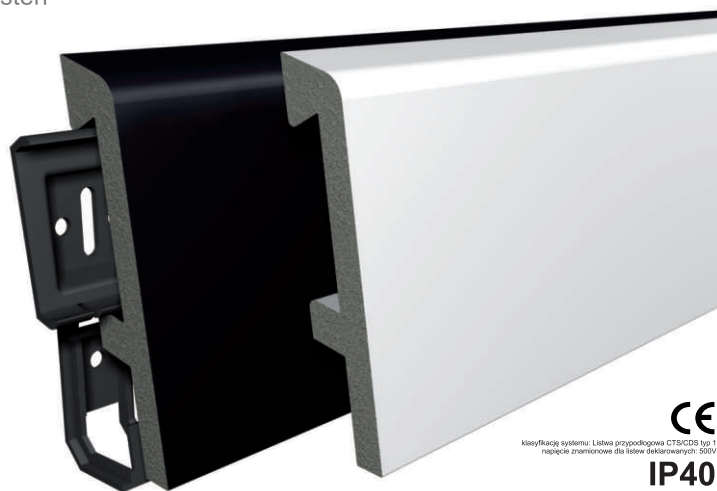

Klasyfikacja systemu: Listwa przypodłogowa CTS/CDS typ 1  
napięcie znamionowe dla listew deklarowanych: 500V

**IP40**

	nr artykułu article number артикул № Artikelnummer	dl. (cm) length (cm) длина (см) Länge (cm)	j.m. unit шт. Einheit	ilość w opak. units / package кол. в упак. Stück / VE	nr koloru colour number цвет № Farbnummer
	<b>CLASSIC</b> <b>A-S80ST</b>	<b>250</b>	szt. pcs шт. Stück	<b>12</b>	<b>W2, B0</b>
	<b>A-S8LC1</b>		kpl. (2 szt.) set (2 pcs) компн (2 шт.) Set (2 Stück)	<b>10</b>	
	<b>A-S8NW1</b>		kpl. (2 szt.) set (2 pcs) компн (2 шт.) Set (2 Stück)	<b>4</b>	
	<b>A-S8NZ1</b>		kpl. (2 szt.) set (2 pcs) компн (2 шт.) Set (2 Stück)	<b>3</b>	
	<b>A-S8ZK1</b>		kpl. (lewo + prawo) set (left + right) компн. (левые + правые) set. (links + rechts)	<b>10</b>	
	<b>A-VICTO-XX-001</b>		kpl. (5 szt.) set (5 pcs) компн (5 шт.) Set (5 Stück)	<b>5</b>	
	<b>A-BFC01</b>		kpl. (24 szt.) set (24 pcs) компн (24 шт.) Set (24 Stück)	<b>8</b>	
	<b>SLIM</b> <b>A-S80ST</b>	<b>250</b>	szt. pcs шт. Stück	<b>12</b>	<b>W2, B0</b>
	<b>A-S8LC2</b>		kpl. (2 szt.) set (2 pcs) компн (2 шт.) Set (2 Stück)	<b>10</b>	
	<b>A-S8NW2</b>		kpl. (2 szt.) set (2 pcs) компн (2 шт.) Set (2 Stück)	<b>4</b>	
	<b>A-S8NZ2</b>		kpl. (2 szt.) set (2 pcs) компн (2 шт.) Set (2 Stück)	<b>4</b>	
	<b>A-S8ZK2</b>		kpl. (lewo + prawo) set (left + right) компн. (левые + правые) set. (links + rechts)	<b>10</b>	
	<b>A-VICTO-XX-002</b>		kpl. (5 szt.) set (5 pcs) компн (5 шт.) Set (5 Stück)	<b>5</b>	
	<b>A-BFC01</b>		kpl. (24 szt.) set (24 pcs) компн (24 шт.) Set (24 Stück)	<b>8</b>	



biały  
белый  
white  
weiß



czarny  
черный  
black  
schwarz

# listwa sokołowa

aspro

Skirting boards  
Плинтусы  
Sockelleisten















powierzchnia dekoracyjna listwy jest pokryta bezbarwnym gruntem co sprawia, że produkt jest przygotowany do malowania



CE

Klasyfikacja systemu: Listwa przypodłogowa CTS/CDS typ 1 napęcznie dla listew deklarowanych: 500V

IP40

	nr artykułu article number артикул № Artikelnummer	dl. (cm) length (cm) длина (см) Länge (cm)	j.m. unit шт. Einheit	ilość w opak. units / package кол. в умяк. Stück / VE	nr koloru colour number цвет № Farbnummer
	<b>CLASSIC</b> <b>A-L8KOM</b>	<b>250</b>	szt. pcs шт. Stück	<b>20</b>	
	<b>A-L8LC1</b>		kpl. (2 szt.) set (2 pcs) компн. (2 шт.) Set (2 Stück)	<b>10</b>	<b>0T, 6T, W2, W6, W7, W8, 55, 61, 9F</b>
	<b>A-L8NW1</b>		kpl. (2 szt.) set (2 pcs) компн. (2 шт.) Set (2 Stück)	<b>4</b>	
	<b>A-L8NZ1</b>		kpl. (2 szt.) set (2 pcs) компн. (2 шт.) Set (2 Stück)	<b>3</b>	
	<b>A-L8ZK1</b>		kpl. (lewo + prawo) set (left + right) компн. (левые + правые) set. (links + rechts)	<b>10</b>	
	<b>A-ASPRQ-XX-001</b>		kpl. (5 szt.) set (5 pcs) компн. (5 шт.) Set (5 Stück)	<b>5</b>	
	<b>A-BFC01</b>		kpl. (24 szt.) set (24 pcs) компн. (24 шт.) Set (24 Stück)	<b>8</b>	
	<b>SLIM</b> <b>A-L8KOM</b>	<b>250</b>	szt. pcs шт. Stück	<b>20</b>	
	<b>A-L8LC2</b>		kpl. (2 szt.) set (2 pcs) компн. (2 шт.) Set (2 Stück)	<b>10</b>	<b>0T, 6T, W2, W6, W7, W8, 55, 61, 9F</b>
	<b>A-L8NW2</b>		kpl. (2 szt.) set (2 pcs) компн. (2 шт.) Set (2 Stück)	<b>4</b>	
	<b>A-L8NZ2</b>		kpl. (2 szt.) set (2 pcs) компн. (2 шт.) Set (2 Stück)	<b>4</b>	
	<b>A-L8ZK2</b>		kpl. (lewo + prawo) set (left + right) компн. (левые + правые) set. (links + rechts)	<b>10</b>	
	<b>A-ASPRQ-XX-002</b>		kpl. (5 szt.) set (5 pcs) компн. (5 шт.) Set (5 Stück)	<b>5</b>	
	<b>A-BFC01</b>		kpl. (24 szt.) set (24 pcs) компн. (24 шт.) Set (24 Stück)	<b>8</b>	



Jesion  
ash  
Ясень  
Asche



dąb  
oak  
дуб  
Eiche



biały  
bełny  
white  
weiß



Jesion  
ash  
Ясень  
Asche



Jesion  
ash  
Ясень  
Asche



orzec  
walnut  
орех  
Walnuss



metalic 1  
metalic 1  
металлик 1  
Metallisch 1



metalic 7  
metalic 7  
металлик 7  
Metallisch 7



pinia  
pine  
Пина  
Pine

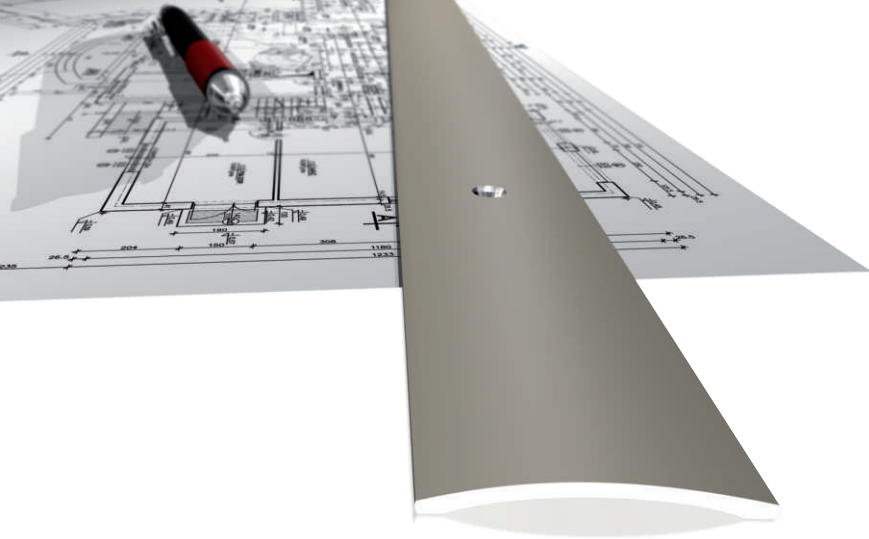

# listwa progowa **aspro**

Transition mouldings  
Переходные профили  
Übergangsprofile

aluminium  
алюминиевый  
Alu

	nr artykułu article number артикул № Artikelnummer	dl. (cm) length (cm) длина (см) Länge (cm)	j.m. unit e. m. Einheit	ilość w opak. units / package кон. в ун.п. Stück / VE	nr koloru colour number цвет № Farbnummer
	1-06227	90	szt. pcs шт. Stück	35	04
		180			90
	1-06280	90	szt. pcs шт. Stück	20	01, 03, 04
		180			270
	1-07697	90	szt. pcs шт. Stück	25	04
		180			90
	1-09165	90	szt. pcs шт. Stück	30	04
		180			90
	1-06226	90	szt. pcs шт. Stück	35	01, 03, 04
		180			



01  
srebrny  
silver  
серебряный  
Silber



03  
złoty  
gold  
золотой  
Gold



04  
szampański  
champagne  
шампанский  
Champagner

# listwa progowa **aspro**

Transition mouldings  
Переходные профили  
Übergangprofile

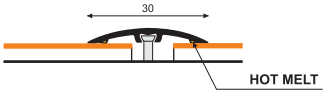

aluminium  
алюминиевый  
Alu

	nr artykułu article number артикул № Artikelnummer	dl. (cm) length (cm) длина (cm) Länge (cm)	j.m. unit e. k. Einheit	ilość w opak. units / package кол. в улек. Stück / VE	nr koloru colour number цвет № Farbnummer
	<b>1-00100</b>	<b>93</b> <b>180</b> <b>270</b>	<b>szt.</b> pcs шт. Stück	<b>30</b>	<b>01, 03, 04</b>
	<b>1-00200</b>	<b>93</b> <b>180</b> <b>270</b>	<b>szt.</b> pcs шт. Stück	<b>25</b>	<b>01, 03</b>
	<b>1-00212</b>	<b>93</b> <b>180</b>	<b>szt.</b> pcs шт. Stück	<b>20</b>	
	<b>1-00400</b>	<b>93</b> <b>180</b>	<b>szt.</b> pcs шт. Stück	<b>30</b>	<b>01, 03</b>
	<b>1-06281</b>	<b>93</b> <b>180</b>	<b>szt.</b> pcs шт. Stück	<b>35</b>	
	<b>1-00300</b>	<b>93</b> <b>180</b>	<b>szt.</b> pcs шт. Stück	<b>20</b>	



**01**  
srebrny  
silver  
серебряный  
Silber



**03**  
złoty  
gold  
золотой  
Gold



**04**  
szampański  
champagne  
шампанский  
Champagner



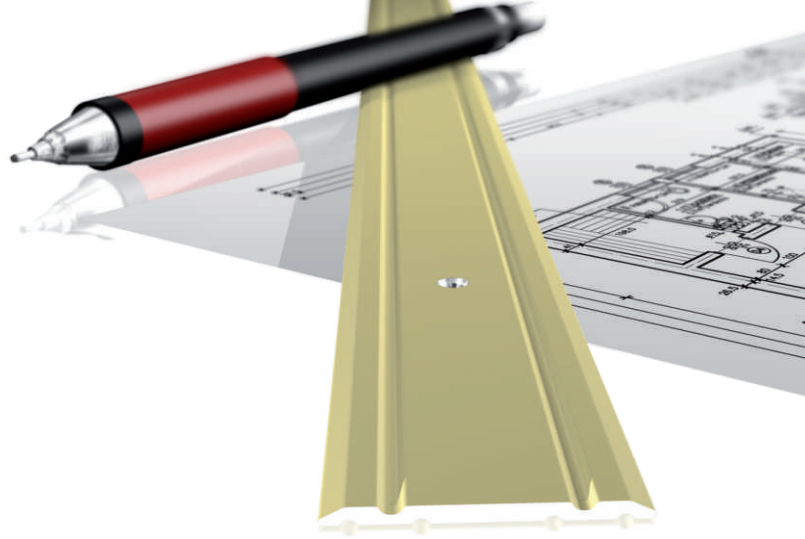

# listwa progowa **BORCK**

Transition mouldings  
Переходные профили  
Übergangprofile

aluminium  
алюминиевый  
Alu



	nr artykułu article number артикул № Artikelnummer	dl. (cm) length (cm) длина (см) Länge (cm)	j.m. unit e.и. Einheit	ilość w opak. units / package кон. в упак. Stück / VE	nr koloru colour number цвет № Farbnummer
	1-12102	90 180 270	szt. pcs шт. Stück	35	01, 03
	1-12103	90 180 270	szt. pcs шт. Stück	35	
	1-12104	90 180	szt. pcs шт. Stück	35	
	E-E1100	90 180	szt. pcs шт. Stück	25	

# listwa progowa

**BORCK**

Transition mouldings  
Переходные профили  
Übergangprofile

aluminium  
алюминиевый  
Alu



01  
srebrny  
silver  
серебряный  
Silber



03  
złoty  
gold  
золотой  
Gold



04  
szampański  
champagne  
шампанский  
Champagner

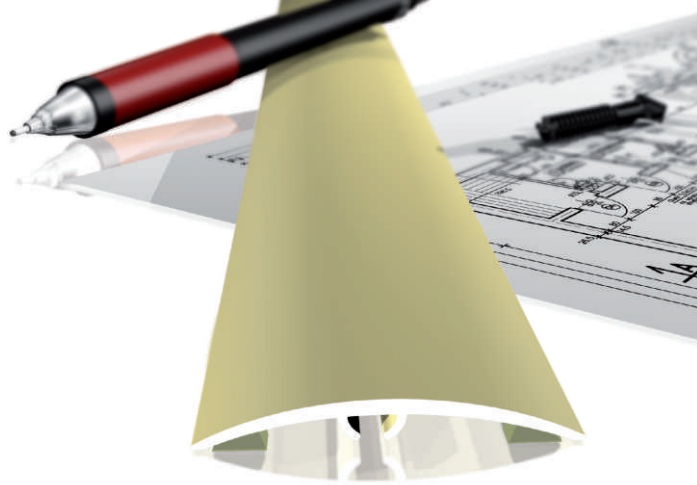

	nr artykułu article number артикул № Artikelnummer	dl. (cm) length (cm) длина (cm) Länge (cm)	j.m. unit e. m. Einheit	ilość w opak. units / package кол. в улек. Stück / VE	nr koloru colour number цвет № Farbnummer
	<b>E-EK202</b>	<b>93 103 180 270</b>	<b>szt. pcs шт. Stück</b>	<b>25</b>	<b>01, 03, 04</b>
	<b>E-EK101</b>	<b>93 103 180 270</b>	<b>szt. pcs шт. Stück</b>	<b>30</b>	
	<b>E-E0100</b>	<b>93 180</b>	<b>szt. pcs шт. Stück</b>	<b>35</b>	
	<b>1-12201</b>	<b>90 180</b>	<b>szt. pcs шт. Stück</b>	<b>25</b>	<b>01, 03</b>
	<b>E-E0300</b>	<b>93 180</b>	<b>szt. pcs шт. Stück</b>	<b>20</b>	

# listwa progowa

**BORCK**

Transition mouldings  
Переходные профили  
Übergangprofile

aluminium-laminat  
aluminium-laminate  
алюминиевый-ламинат  
Alu-laminieren



	nr artykułu article number артикул № Artikelnummer	dl. (cm) length (cm) длина (cm) Länge (cm)	j.m. unit e.t. Einheit	ilość w opak. units / package кол. в уклад. Stück / VE	nr koloru colour number цвет № Farbnummer
	<b>E-EK222</b>	<b>93</b> <b>103</b> <b>180</b> <b>270</b>	<b>szt.</b> <b>pcs</b> <b>ut.</b> <b>Stück</b>	<b>25</b>	<b>2E, 3E, 6E, 9E, 0P</b> <b>1P, 2P, 3P, 4P, 6P</b> <b>7P, 8P, 9P, 0U, 15</b>
	<b>E-EK111</b>	<b>93</b> <b>103</b> <b>180</b> <b>270</b>	<b>szt.</b> <b>pcs</b> <b>ut.</b> <b>Stück</b>	<b>30</b>	
	<b>E-E0200</b>	<b>93</b> <b>180</b>	<b>szt.</b> <b>pcs</b> <b>ut.</b> <b>Stück</b>	<b>35</b>	<b>0E, 1E, 2E, 3E</b> <b>6E, 7E, 9E, 1P</b> <b>2P, 3P, 15</b>
	<b>1-12201</b>	<b>90</b> <b>180</b>	<b>szt.</b> <b>pcs</b> <b>ut.</b> <b>Stück</b>	<b>25</b>	
	<b>E-E0400</b>	<b>93</b> <b>93</b> <b>180</b>	<b>szt.</b> <b>pcs</b> <b>ut.</b> <b>Stück</b>	<b>20</b>	<b>6E, 7E</b> <b>0E, 1E, 2E, 3E, 2P</b>

<b>0E</b> buk m1 beech m1 Бук м1 Buche m1	<b>1E</b> buk m2 beech m2 Бук м2 Buche m2	<b>2E</b> dąb m1 oak m1 дуб м1 Eiche m1	<b>3E</b> dąb m2 oak m2 дуб м2 Eiche m2	<b>6E</b> kasztan chestnut каштан Kastanie	<b>7E</b> mahoni m1 mahogany m1 махагон м1 Mahagoni m1	<b>9E</b> orzeczek m1 walnut m1 орzech м1 Walnuss m1	<b>0P</b> wenge wenge seive Wenge	<b>1P</b> klon maple sneak Ahorn	<b>2P</b> dąb oak дуб Eiche
<b>3P</b> dąb oak дуб Eiche	<b>4P</b> dąb oak дуб Eiche	<b>6P</b> dąb biały oak white дуб белый WeißEiche	<b>7P</b> dąb oak дуб Eiche	<b>8P</b> dąb oak дуб Eiche	<b>9P</b> dąb m4 oak m4 дуб м4 Eiche m4	<b>0U</b> dąb tabacco tobacco oak дуб табак Eiche tabak	<b>15</b> dąb oak дуб Eiche		

# listwa progowa



Transition mouldings  
Переходные профили  
Übergangprofile

laminat



nr artykułu article number артикул № Artikelnummer	dl. (cm) length (cm) длина (см) Länge (cm)	j.m. unit e. m. Einheit	ilość w opak. units / package кол. в упак. Stück / VE	nr koloru colour number цвет № Farbnummer
D-P0100	100 200	szt. pcs шт. Stück	100	01, 0E, 1E, 2E, 3E, 5E, 6E 7E, 9E, 0P, 1P, 2P, 3P, 4P 5P, 6P, 7P, 8P, 0U, 15, 16
D-P0200	100 200	szt. pcs шт. Stück	80	01, 0E, 1E, 2E, 3E, 5E, 6E 7E, 9E, 0P, 1P, 2P, 3P, 4P 5P, 6P, 7P, 8P, 9P, 0U, 15, 16
D-P0300	100 200	szt. pcs шт. Stück	100	
D-PS400	100 200	szt. pcs шт. Stück	50	0E, 1E, 2E, 3E, 5E, 6E 7E, 9E, 0P, 2P, 4P, 0U, 15, 16

01	0E	1E	2E	3E	5E	6E	7E	9E	0P	1P
srebrny silver серебряный Silber	buk m1 beech m1 бук м1 Buche m1	buk m2 beech m2 бук м2 Buche m2	dąb m1 oak m1 дуб м1 Eiche m1	dąb m2 oak m2 дуб м2 Eiche m2	wiąz m1 elm m1 ясень м1 Ulme m1	kasztan m1 chestnut m1 каштан м1 Kastan m1	mahoni m1 mahogany m1 махагон м1 Mahagoni m1	orzeczn m1 walnut m1 орех м1 Walnuss m1	wenge wenge венге Wenge	klon maple клен Ahorn
2P	3P	4P	5P	6P	7P	8P	9P	0U	15	16
dąb oak дуб Eiche	dąb oak дуб Eiche	dąb oak дуб Eiche	jesion ash ясень Esche	dąb biały oak white дуб белый WeißEiche	dąb oak дуб Eiche	dąb oak дуб Eiche	dąb m4 oak m4 дуб м4 Eiche m4	dąb tabacco tabacco oak дуб табак Eiche tabak	dąb oak дуб Eiche	klon maple клен Ahorn

# listwa

specjalistyczna



Special profiles  
Плнтусы специальные  
Spezialleisten

aluminium  
алюминиевый  
Alu

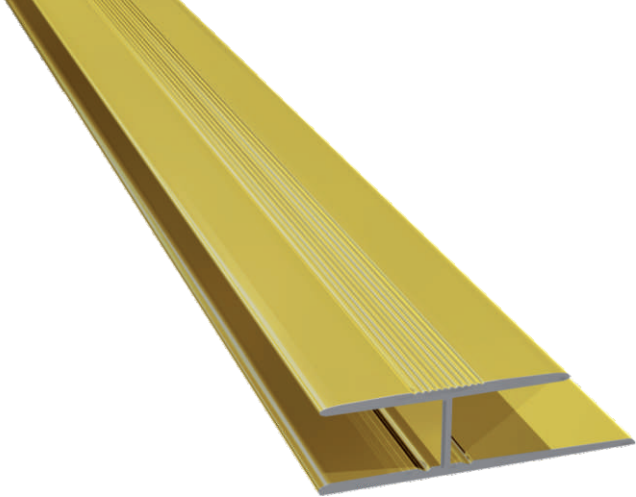

	nr artykułu article number артикул № Artikelnummer	dl. (cm) length (cm) длина (cm) Länge (cm)	j.m. unit e.и. Einheit	ilość w opak. units / package кол. в унак. Stück / VE	nr koloru colour number цвет № Farbnummer
	E-E0500	90 180	szt. pcs шт. Stück	20	
	E-E0700	90 180	szt. pcs шт. Stück	25	01, 03
	E-E1200	90 180	szt. pcs шт. Stück	20	

**listwa**  
specjalistyczna

**MYCK**

Special profiles  
Плитусы специальные  
Spezialleisten

laminat

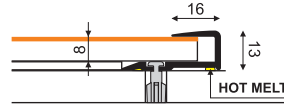
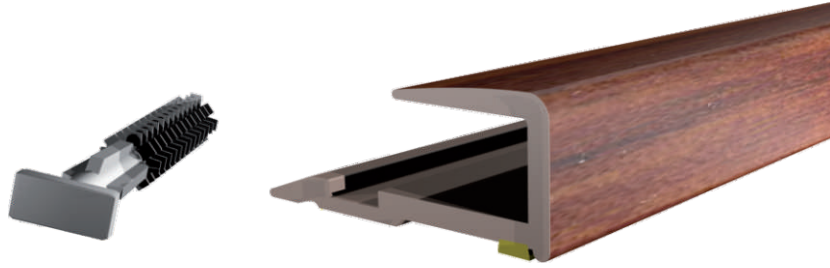

nr artykułu article number артикул № Artikelnummer	dl. (cm) length (cm) длина (см) Länge (cm)	j.m. unit с.и. Einheit	ilość w opak. units / package кол. в уклад. Stück / VE	nr koloru colour number цвет № Farbnummer
<b>D-Z0200</b>	<b>100</b> <b>200</b>	szt. pcs шт. Stück	<b>80</b>	<b>0E, 1E, 2E, 3E, 5E</b> <b>6E, 7E, 9E, 0P, 2P</b> <b>4P</b>

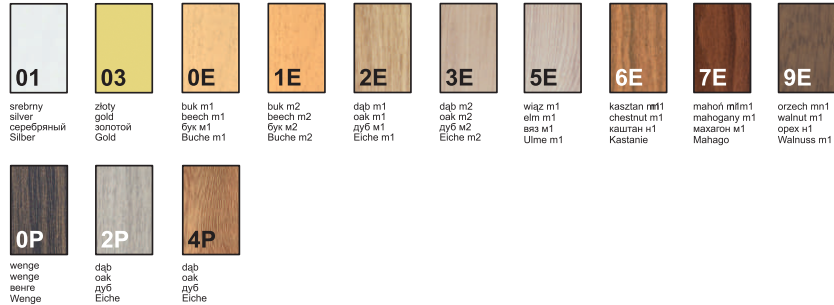

# listwa

specjalistyczna

**volt@**

Special profiles  
Плинтусы специальные  
Spezialleisten

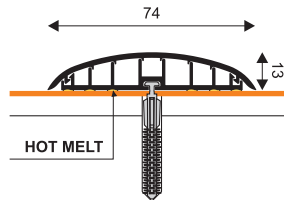

nr artykułu  
article number  
артикул №  
Artikelnummer

dl. (cm)  
length (cm)  
длина (cm)  
Länge (cm)

j.m.  
unit  
ед.из.  
Einheit

ilość w opak.  
units / package  
кол. в упак.  
Stück / VE

nr koloru  
colour number  
цвет №  
Farbnummer

V-VOLTA

100  
200

szt.  
pcs  
шт.  
Stück

28

F6, F9, G0, G3  
62, H6, K7, K5  
J2, W6

tampondruk



**F6**

wiąz n1  
elm n1  
ess n1  
Ulm n1



**F9**

pinia n1  
elm n1  
Табла n1  
Pinie n1



**G0**

dąb n3  
oak n3  
дуб n3  
Eiche n3



**G3**

dąb n4  
oak n4  
дуб n4  
Eiche n4



**62**

metalic 1  
metallic 1  
металек 1  
Metallisch 1



**H6**

dąb n11  
oak n11  
дуб n11  
Eiche n11



**K7**

dąb oak  
oak  
дуб oak  
Eiche



**K5**

dąb oak  
oak  
дуб oak  
Eiche



**J2**

biały  
белый  
white  
weiß



**W6**

czarny  
черный  
black  
schwarz

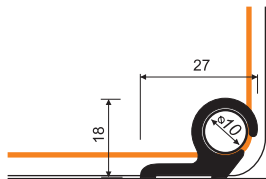

nr artykułu article number артикул № Artikelnummer	dl. (cm) length (cm) длина (см) Länge (cm)	j.m. unit e.и. Einheit	ilość w opak. units / package кол. в упак. Stück / VE	nr koloru colour number цвет № Farbnummer
---	---	---------------------------------	--	--

E-E1000

80  
90  
100  
140

kpl. (2szt.)  
set (2pcs.)  
компл. (2шт.)  
Set. (2Stück)

15

01, 02

pret  
schodowy

**BORCK**

Stair carpet rods  
Лестничные стержни  
Treppenläuferstangen

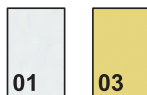

01	03
srebrny silver серебряный Silber	złoty gold золотой Gold



# kątownik schodowy

aspro®



Stair nosing profiles  
Угловой профиль  
Treppenstufenprofile

aluminium  
алюминиевый  
Alu

	nr artykułu article number артикул № Artikelnummer	dl. (cm) length (cm) длина (cm) Länge (cm)	j.m. unit e.m. Einheit	ilość w opak. units / package кол. в унак. Stück / VE	nr koloru colour number цвет № Farbnummer
	<b>E-E6316</b>	<b>135</b> <b>270</b>	szt. pcs wr. Stück	<b>30</b>	<b>2E, 6E, 9E, 1P</b> <b>2P, 6P</b>
	<b>1-07696</b>	<b>90</b> <b>180</b> <b>270</b>	szt. pcs wr. Stück	<b>25</b>	<b>01, 03</b>
		<b>90</b> <b>180</b>	szt. pcs wr. Stück	<b>25</b>	<b>04</b>
		<b>90</b>	szt. pcs wr. Stück	<b>25</b>	<b>06</b>
	<b>1-09167</b>	<b>90</b> <b>180</b> <b>270</b>	szt. pcs wr. Stück	<b>15</b>	<b>01, 03</b>
		<b>90</b>	szt. pcs wr. Stück	<b>15</b>	<b>04</b>
	<b>1-07669</b>	<b>90</b> <b>180</b>	szt. pcs wr. Stück	<b>15</b>	<b>01</b>
		<b>90</b> <b>180</b>	szt. pcs wr. Stück	<b>15</b>	<b>03</b>
	<b>1-06316</b>	<b>90</b> <b>180</b>	szt. pcs wr. Stück	<b>30</b>	<b>01, 03</b>
		<b>90</b> <b>180</b>	szt. pcs wr. Stück	<b>30</b>	<b>04</b>



# kątownik schodowy aspro®

Stair nosing profiles  
Угловой профиль  
Treppenstufenprofile

aluminium  
алюминиевый  
Alu

	nr artykułu article number артикул № Artikelnummer	dl. (cm) length (cm) длина (cm) Länge (cm)	j.m. unit e. m. Einheit	ilość w opak. units / package кол. в упак. Stück / VE	nr koloru colour number цвет № Farbnummer
	<b>GC</b> 1-09199	90 270		15	03, P0
	<b>GS</b> 1-09299	90 270	szt. pcs шт. Stück	15	P0
	<b>GB</b> 1-09399	90 270		15	P0
	1-06437	90 135 180 270	szt. pcs шт. Stück	20	01, 03
	<b>GC</b> 1-09188	90 270		15	P0
	<b>GS</b> 1-09288	90	szt. pcs шт. Stück	15	P0
	<b>GB</b> 1-09388	90 270		15	P0



01  
srebrny  
silver  
серебряный  
Silber



03  
złoty  
gold  
золотой  
Gold



P0  
srebrny polerowany  
silver polished  
серебро полированное  
Silber Poliert



GC  
czarny  
black  
чёрный  
Schwarz



GS  
szary  
grey  
серая  
Grau



GB  
brąz  
brown  
коричневая  
braun

# kątownik schodowy

**BORCK**

Stair nosing profiles  
Угловой профиль  
Treppenstufenprofile

aluminium  
алюминиевый  
Alu

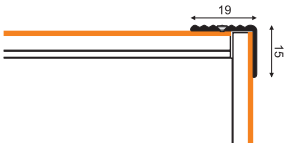
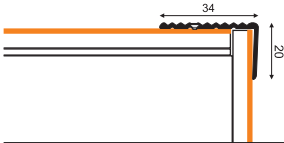
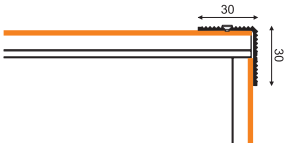
	nr artykułu article number артикул № Artikelnummer	dl. (cm) length (cm) длина (см) Länge (cm)	j.m. unit e.и. Einheit	ilość w opak. units / package кол. в унак. Stück / VE	nr koloru colour number цвет № Farbnummer
	1-12105	90 180 270	szt. pcs шт. Stück	25	
	1-12106	90 180	szt. pcs шт. Stück	20	01, 03
	E-E0900	90 180	szt. pcs шт. Stück	15	



01  
srebrny  
silver  
серебряный  
Silber



03  
złoty  
gold  
золотой  
Gold



04  
szampański  
champagne  
шампанский  
Champagner

# kątownik schodowy



Stair nosing profiles  
Угловой профиль  
Treppenstufenprofile

laminat

	nr artykułu article number артикул № Artikelnummer	dl. (cm) length (cm) длина (cm) Länge (cm)	j.m. unit e.j. Einheit	ilość w opak. units / package кол. в упак. Stück / VE	nr koloru colour number упок № Farbnummer
	<b>D-K0100</b>	100	szt. pcs шт. Stück	40	0E, 1E, 2E, 3E, 5E, 6E 7E, 9E 0P, 2P, 4P
		200			0E, 1E, 2E, 3E, 5E 6E, 9E 0P, 2P, 4P
	<b>D-K0200</b>	100	szt. pcs шт. Stück	40	0E, 2E, 3E, 5E, 6E 9E 0P, 2P, 4P, 6P
		200			0E, 2E, 3E, 9E 0P 2P, 4P, 6P
	<b>D-K0300</b>	100	szt. pcs шт. Stück	70	7E
		200			7E, 4P
	<b>D-K0500</b>	100	szt. pcs шт. Stück	80	6E, 9E, 1P, 3P, 5P, 6P, 16 7P, 8P, 9P
		200			
	<b>D-K0400</b>	100	szt. pcs шт. Stück	80	0E, 1E, 2E, 3E, 5E 6E, 7E, 9E, 0P, 1P 2P, 3P, 4P, 5P, 6P 16, 7P, 8P, 9P
		200			

<b>0E</b> buk m1 beech m1 Бук m1 Buche m1	<b>1E</b> buk m2 beech m2 Бук m2 Buche m2	<b>2E</b> dąb m1 oak m1 дуб m1 Eiche m1	<b>3E</b> dąb m2 oak m2 дуб m2 Eiche m2	<b>5E</b> wiaz m1 elm m1 яс m1 Ulme m1	<b>6E</b> kasztan m1 chestnut m1 каштан m1 Kastanie m1	<b>7E</b> mahoni m1 mahogany m1 махови m1 Mahagoni m1	<b>9E</b> orzeczn m1 walnut m1 орех m1 Walnuss m1	<b>0P</b> wenge wenge сери Wenge	<b>1P</b> klon maple клен Ahorn
<b>2P</b> dąb oak дуб Eiche	<b>3P</b> dąb oak дуб Eiche	<b>4P</b> dąb oak дуб Eiche	<b>5P</b> jesion ash ясен Esche	<b>6P</b> dąb biały oak white дуб белы WeißEiche	<b>16</b> klon maple клен Ahorn	<b>7P</b> dąb oak дуб Eiche	<b>8P</b> dąb oak дуб Eiche	<b>9P</b> dąb m4 oak m4 дуб m4 Eiche m4	

# listwa

wykończeniowa

**aspro**

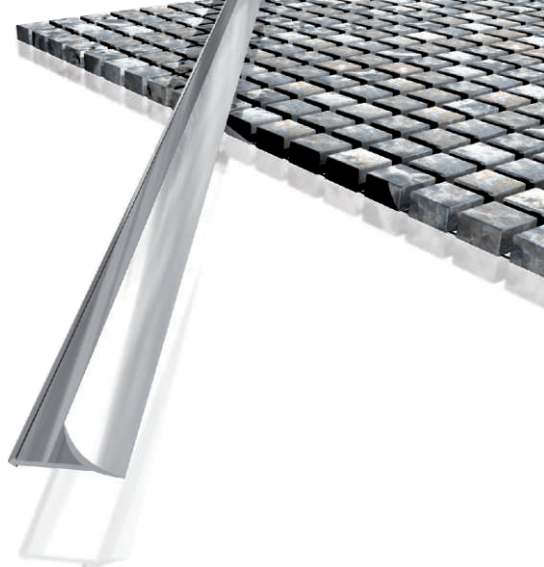

Standard tile trims  
Плнтусы отделочные  
Abschlussleisten

aluminium  
алюминиевый  
Alu

	nr artykułu article number артикул № Artikelnummer	dl. (cm) length (cm) длина (cm) Länge (cm)	j.m. unit ед.м. Einheit	ilość w opak. units / package кол. в упак. Stück / VE	nr koloru colour number цвет № Farbnummer
	<b>6-00615</b>	<b>250</b>	<b>szt.</b> pcs шт. Stück	<b>20</b>	<b>00</b>
	<b>6-00631</b>	<b>250</b>	<b>szt.</b> pcs шт. Stück	<b>20</b>	<b>00</b>
	<b>GC 1-09177</b>	<b>250</b>	<b>szt.</b> pcs шт. Stück	<b>12</b>	<b>00</b>
	<b>GS 1-09277</b>	<b>250</b>		<b>12</b>	<b>00</b>
	<b>GB 1-09377</b>	<b>250</b>		<b>12</b>	<b>00</b>
	<b>GE 1-09477</b>	<b>250</b>		<b>12</b>	<b>00</b>
	<b>GC 1-09155</b>	<b>250</b>	<b>szt.</b> pcs шт. Stück	<b>12</b>	<b>00</b>
	<b>GS 1-09255</b>	<b>250</b>		<b>12</b>	<b>00</b>
	<b>GB 1-09355</b>	<b>250</b>		<b>12</b>	<b>00</b>
	<b>6-00612</b>	<b>250</b>	<b>szt.</b> pcs шт. Stück	<b>20</b>	<b>P0, 04</b>
	<b>6-00613</b>	<b>125</b>	<b>szt.</b> pcs шт. Stück	<b>20</b>	<b>01, 04</b>
		<b>250</b>		<b>20</b>	<b>P0, 01, 04</b>
	<b>6-00608</b>	<b>250</b>	<b>szt.</b> pcs шт. Stück	<b>20</b>	<b>00</b>
	<b>6-00630</b>	<b>250</b>	<b>szt.</b> pcs шт. Stück	<b>20</b>	<b>00, 01, 03</b>



00  
alumiowy  
aluminium  
алюминиевый  
Aluminium



01  
srebrny  
silver  
серебряный  
Silber



03  
złoty  
gold  
золотой  
Gold



04  
szampański  
silver  
шампанский  
Champagner



P0  
srebrny polerowany  
silver polished  
серебро полированное  
Silber Poliert



GC  
czarny  
black  
чёрный  
Schwarz



GS  
szary  
grey  
серый  
Grau



GB  
brąz  
brown  
коричневая  
braun



GE  
beż  
beige  
бежевая  
beige

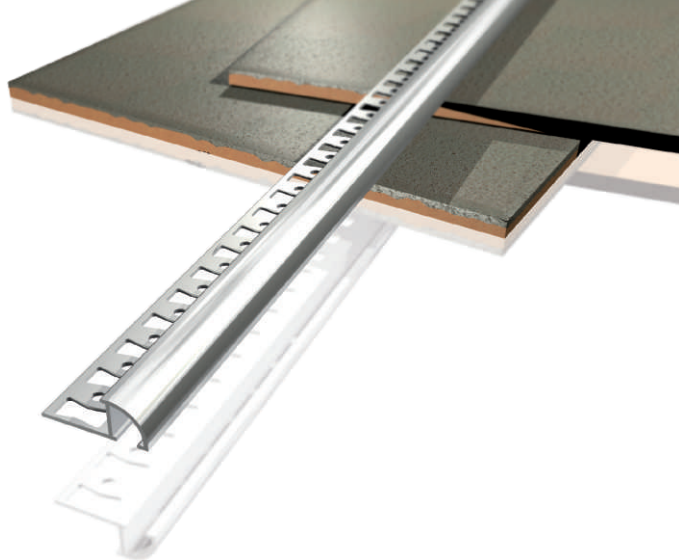

# listwa wykończeniowa

**aspro®**

Standard tile trims  
Плнтусы отделочные  
Abschlussleisten

aluminium  
алюминиевый  
Alu

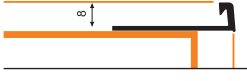
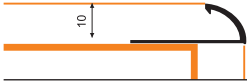
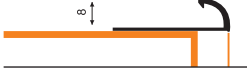
	nr artykułu article number артикул № Artikelnummer	dl. (cm) length (cm) длина (cm) Länge (cm)	j.m. unit e. m. Einheit	ilość w opak. units / package кол. в унпк. Stück / VE	nr koloru colour number цвет № Farbnummer
	6-00600	250	szt. pcs шт. Stück	20	00, 01, 03, 04
	6-00601	250	szt. pcs шт. Stück	20	00, 01, 03
	6-00602	250	szt. pcs шт. Stück	20	00, 01, 03, 04
	6-00603	250	szt. pcs шт. Stück	20	00, 01, 03
	6-00611	250	szt. pcs шт. Stück	20	00, 03, P0



00  
aluminiumowy  
aluminium  
алюминиевый  
Aluminium



01  
srebrny  
silver  
серебряный  
Silber



03  
złoty  
gold  
золотой  
Gold



04  
szampański  
champagne  
шампанский  
Champagner



P0  
srebrny polerowany  
silver polished  
серебро полированное  
Silber Poliert

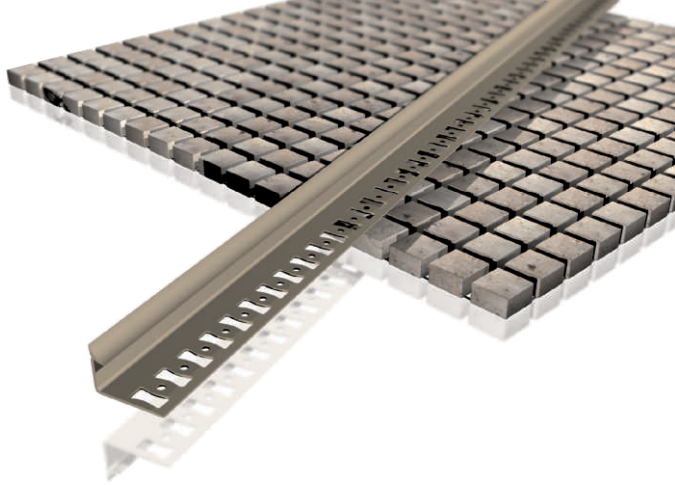

	nr artykułu article number артикул № Artikelnummer	dl. (cm) length (cm) длина (см) Länge (cm)	j.m. unit с.м. Einheit	ilość w opak. units / package кол. в унак. Stück / VE	nr koloru colour number цвет № Farbnummer
	<b>F-FSZ08</b>	<b>250</b>	szt. pcs шт. Stück	<b>80</b>	<b>L0, L1, L2, L3 L4, L5</b>
	<b>F-FSZ10</b>	<b>250</b>	szt. pcs шт. Stück	<b>80</b>	

# listwa

wykończeniowa **aspro**

Standard tile trims  
Плинтусы отделочные  
Abschlussleisten

PCV



# listwa

wykończeniowa



Standard tile trims  
Плнтусы отделочные  
Abschlussleisten

aluminium  
алюминиевый  
Alu

	nr artykułu article number артикул № Artikelnummer	dl. (cm) length (colour) длина (цвет) Länge (cm)	j.m. unit e.k. Einheit	ilość w opak. units / package кол. в утпк. Stück / VE	nr koloru colour number цвет № Farbnummer
	6-00609	250	szt. pcs шт. Stück	20	00, P0, 7E, 15, 22
	6-00612	250	szt. pcs шт. Stück	20	04, 15, 16, 6E, 7E 9E, 0P, 1P, 2P, 4P 5P, 6P, P0, 7P, 8P 9P
	6-00613	125 250	szt. pcs шт. Stück	20	01, 04, 15, 1P, 2P 4P, 6P, 7E, 9E, 0E 7P, 9P
	6-00617	250	szt. pcs шт. Stück	20	00
	2-27388	250	szt. pcs шт. Stück	12	00, 15, 16, 7E, 9E 0P, 1P, 22
	2-29166	250	szt. pcs шт. Stück	12	00

01 srebrny silver серебряный Silber	04 szampański champagne шампанский Champagner	00 aluminowy aluminium алюминиевый Aluminium	P0 srebrny polerowany silver polished серебро полированное Silber Poliert	15 dąb oak дуб Eiche	16 klon maple клен Ahorn	6E kasztan m1 chestnut m1 каштан m1 Kastanie m1	7E mahoni m1 mahogany m1 махагон m1 Mahagoni m1	9E orzech mn1 walnut m1 орех m1 Walnuss m1	0P wenge wenge венге Wenge
1P klon maple клен Ahorn	2P dąb oak дуб Eiche	4P dąb oak дуб Eiche	5P jesion ash ясень Esche	6P dąb biały oak white дуб белый Weisseiche	7P dąb oak дуб Eiche	8P dąb oak дуб Eiche	9P dąb m4 oak m4 дуб m4 Eiche m4	22 buk bawaria Bavarian beech бук Бавария Bayerische Buche	





# listwa dekoracyjna



Decorative profiles  
Плнтусы декоративные  
Dekoprofile/ Bordüren

aluminium  
алюминиевый  
Alu





	nr artykułu article number артикул № Artikelnummer	dl. (cm) length (cm) длина (см) Länge (cm)	j.m. unit с.п. Einheit	ilość w opak. units / package кол. в упак. Stück / VE	nr koloru colour number цвет № Farbnummer
	<b>F-ADPC1</b>	<b>250</b>	szk. pcs шт. Stück	<b>1</b>	<b>A0, A1, A2</b>
	<b>F-ADPA1</b>	<b>250</b>	szk. pcs шт. Stück	<b>1</b>	<b>A0, A1, A2</b>
	<b>F-ADPB1</b>	<b>250</b>	szk. pcs шт. Stück	<b>1</b>	<b>A0, A1</b>

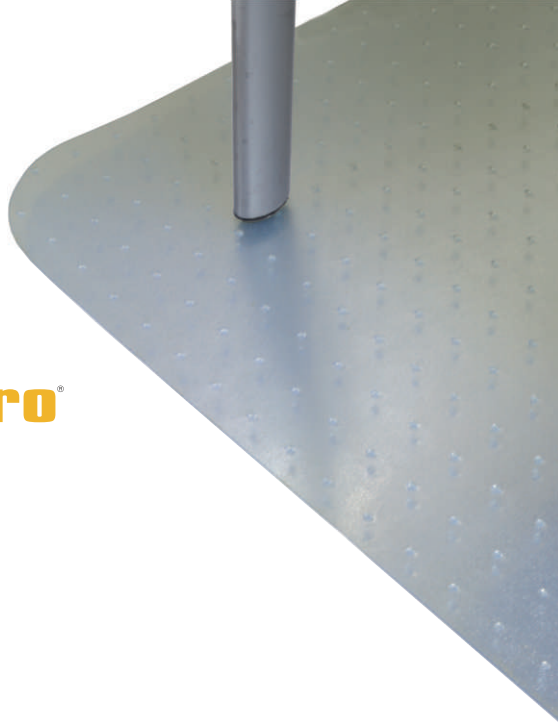

# akcesoria **aspro**

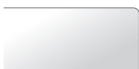
Accessories  
Принадлежности  
Zubehör



	rozmiar size размер Größe	grubość thickness толщина Dicke	nr artykułu article number артикул № Artikelnummer	j.m. unit с.ш. Einheit	ilość w opak. units / package кол. в утук. Stück / VE	color colour цвет Farbe	uwagi comments примечания Kommentare
	1200 x 900 mm	1,5 mm	<b>A-MATA1-XX-015</b>	szt. pcs шт. Stück	<b>7</b>	przezroczysty transparent Прозрачный Transparente	
	1200 x 900 mm	2 mm	<b>A-MATA1-XX-020</b>	szt. pcs шт. Stück	<b>5</b>		<b>Mata ochronna</b> wykonane z PVC o dużej przezroczystości, odporne na ścieranie i zarysowania, antypoślizgowe, stabilne na podłodze, łatwe do utrzymania w czystości. <b>Floor protection mat</b> made of PVC with great transparency, abrasion and scratch resistant, anti-slip, stable on the floor, easy to keep clean. <b>Защитный коврик</b> изготовленные из ПВХ с большой прозрачностью. Устойчивые против истиранию и царапином. Устойчивые на полу. Простые для удержания в чистоте. <b>Bodenschutzmatte</b> aus PVC. Kratzfest und Transparent, Anti-Rutsch Eigenschaften, liegt stabil auf dem Boden, leicht zu reinigen.
	1200 x 900 mm	1,5 mm	<b>A-MATA3-XX-015</b>	szt. pcs шт. Stück	<b>7</b>	przezroczysty (grawer) transparent (engraver) прозрачный (гравёр) transparent (Kupferstecher)	
	1200 x 900 mm	2 mm	<b>A-MATA3-XX-020</b>	szt. pcs шт. Stück	<b>5</b>		
	1200 x 900 mm	1,5 mm	<b>A-MATA4-XX-015</b>	szt. pcs шт. Stück	<b>7</b>	kawa (grawer) coffee (engraver) кофе (гравёр) Kaffee (Kupferstecher)	
	1200 x 900 mm	2 mm	<b>A-MATA2-XX-020</b>	szt. pcs шт. Stück	<b>4</b>	przezroczysty transparent Прозрачный Transparente	

# akcesoria

Accessories  
Принадлежности  
Zubehör

**PROFI BASE**<sup>®</sup>

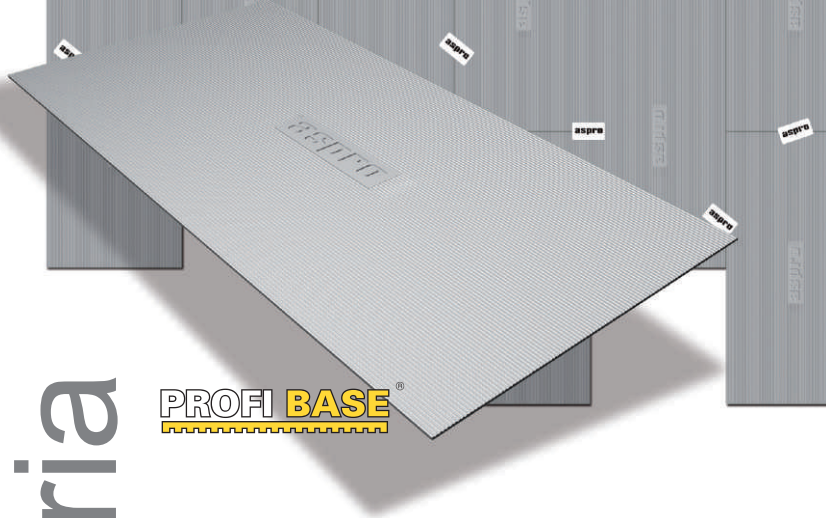

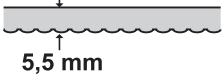
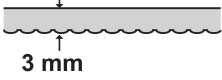
rozmiar size размер Größe	nr artykułu article number артикул № Artikelnummer	j.m. unit e.и. Einheit	ilość w opak. units / package кол. в упак. Stück / VE	color colour цвет Farbe	uwagi comments применения Kommentare
1000 x 500 mm	<b>A-CDA06-94-001</b>	kpl. (4m <sup>2</sup> ) set. (4m <sup>2</sup> ) компл. (4m <sup>2</sup> ) Set. (4m <sup>2</sup> )	<b>13</b> <b>(52 m<sup>2</sup>)</b>	szary gręу серая Grau	<b>Polistyrenowy podkład izolacyjny</b> Polystyrene insulation base Полиуретановая подложка Styroporplatte  <b>5,5 mm</b>
1000 x 500 mm	<b>A-CDA03-94-001</b>	kpl. (5m <sup>2</sup> ) set. (5m <sup>2</sup> ) компл. (5m <sup>2</sup> ) Set. (5m <sup>2</sup> )	<b>18</b> <b>(90 m<sup>2</sup>)</b>	szary gręу серая Grau	<b>Polistyrenowy podkład izolacyjny</b> Polystyrene insulation base Полиуретановая подложка Styroporplatte  <b>3 mm</b>

# akcesoria

Accessories  
Принадлежности  
Zubehör

aspro®



	nr artykułu article number артикул № Artikelnummer	j.m. unit в.и. Einheit	ilość w opak. units / package кол. в упак. Stück / VE	kolor colour цвет Farbe	uwagi comments применения Kommentare
	<b>A-80001-01</b>	szt. pcs шт. Stück	6	<b>001</b> <b>002</b> <b>003</b> <b>004</b>	<b>Odbojniki do drzwi przyciskane.</b> Metalowa powierzchnia galwanizowana. Zabezpiecza przed obciążeniem ścian, przyciskany do podłoża. <b>Screw-fixed door bumpers.</b> Galvanized metal surface, prevents wall damage, screwed to the floor surface.
	<b>A-80004-01</b>	szt. pcs шт. Stück	6		<b>Odbijniki drzwi przykręcane.</b> Metalliczna galwanizowana powierzchnia, предохраняют стены от обивания, прикручиваются к полу. <b>Verschraubbare Türstopper</b> Verzinkte Metalloberfläche, schützt die Wand vor Schäden, verschraubbar mit dem Boden
	<b>A-CCH01</b>	szt. pcs шт. Stück	6	<b>15</b> <b>24</b> <b>30</b> <b>9E</b>	<b>Odbojniki do drzwi samoprzylepne. EKO</b> Wykonana z naturalnego drewna. Zabezpiecza przed obciążeniem ścian, klejony do podłoża. <b>Self-adhesive door bumpers. Manufactured from natural wood,</b> prevents wall damage, glued to the floor surface. <b>EKO</b> <b>Odbijniki drzwi samoklejące.</b> Изготовлены из натурального дерева, предохраняют стены от обивания, клеятся к полу. <b>ЭКО</b> <b>Selbstklebende Türstopper. ÖKO</b> Hergestellt aus Holz, schützt vor Wandbeschädigungen, wird auf dem Boden verklebt.
	<b>A-80012-01</b>	szt. pcs шт. Stück	6	<b>TR</b>	<b>Odbojniki do drzwi samoprzylepne.</b> Wykonane z akrylu. Zabezpiecza przed obciążeniem ścian, klejony do podłoża. <b>Self-adhesive door bumpers. Made of acrylic, self adhesive.</b> <b>Odbijniki drzwi samoklejące.</b> Изготовлены из акрила, предохраняют стены от обивания, клеятся к полу. <b>Selbstklebende Türstopper.</b> Selbstklebender Türstopper aus Acryl.
	<b>A-80013-01</b> ( x 2 )	kpl. set компл. Set	12	<b>TR</b> <b>W2</b> <b>L2</b>	<b>Odbojnik ścienny samoprzylepny .</b> Wykonane z PP. Zabezpiecza przed obciążeniem ścian, klejony na ścianę. <b>Self-adhesive wall bumper.</b> Made of PP. Selfadhesive. <b>Odbijniki drzwi samoklejące.</b> Изготовлены из PP, предохраняют стены от обивания, клеятся к полу. <b>Selbstklebende Türstopper.</b> Wand-Türstopper aus PP.
	<b>A-80013-01</b> ( x 2 )	kpl. set компл. Set	24		
	<b>A-80014-01</b> ( x 2 )	kpl. set компл. Set	12	<b>TR</b>	<b>Odbojnik klamkowy.</b> Wykonany z akrylu. Zabezpiecza przed obciążeniem ścian. Nakładany na klamkę. <b>Door Handle Bumper.</b> Made of acrylic. It protects wall from damage. It is put on the handle. <b>Odbijnik na drzwiową ручkę.</b> Изготовлен из акрила. Защищает стены от повреждений. Накладывается на дверную ручку. <b>Türstopper für Türklinke.</b> Aus Acryl hergestellt. Schützt vor Wandschäden. Man befestigt ihn auf der Türklinke.



**001**  
srebrny  
silver  
серебряный  
Silber



**002**  
srebrny mat  
silver mat  
серебро мат.  
Silber matt



**003**  
złoty  
gold  
золотой  
Gold



**004**  
antyk  
antique  
античный  
Antike



**15**  
dąb  
oak  
дуб  
Eiche



**24**  
mahogany  
maharon  
махагон  
Mahagoni



**30**  
jasny buk  
light beech  
светлый бук  
Buche hell



**9E**  
orzech mn1  
walnut m1  
орех м1  
Walnuss m1



**TR**  
przezroczysty  
transparent  
прозрачный  
transparent



**W2**  
biały  
white  
белый  
weiß



**L2**  
beż  
beige  
бежевый  
beige

# akcesoria

aspro®

Accessories  
Принадлежности  
Zubehör

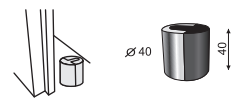
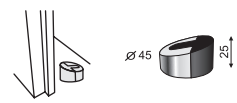
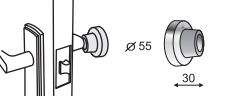
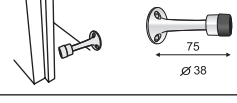
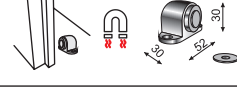
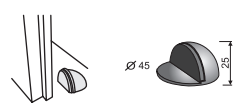

	nr artykułu article number артикул № Artikelnummer	j.m. unit e.и. Einheit	ilość w opak. units / package кол. в упак. Stück / VE	kolor colour цвет Farbe	uwagi comments применения Kommentare
	<b>A-80007-01</b>	szt. pcs шт. Stück	<b>6</b>	<b>001 002</b>	<b>Odbojniki do drzwi przykręcane.</b> Zabezpiecza przed obiciem ścian. Metalowa powierzchnia galwanizowana. <b>Screw-fixed door bumpers.</b> Galvanized metal surface, prevents wall damage. <b>Отбойники дверей прикручивающиеся.</b> Металлическая гальванизованная поверхность предохраняют стены от обитания.
	<b>A-80006-01</b>	szt. pcs шт. Stück	<b>6</b>	<b>001 002</b>	<b>Verschraubbare Türstopper.</b> Verzinkte Metalloberfläche, schützt vor Beschädigung der Wand
	<b>A-80010-20</b>	szt. pcs шт. Stück	<b>6</b>	<b>020</b>	<b>Odbojniki do drzwi przykręcane do ściany</b> Door bumper fixed to wall Отбойник дверей крепленный к стене Türpuffer für die Wand.
	<b>A-80005-01</b>	szt. pcs шт. Stück	<b>6</b>	<b>001 002</b>	
	<b>A-80008-01</b>	szt. pcs шт. Stück	<b>6</b>	<b>001 002</b>	<b>Odbojniki z magnesem blokującym drzwi.</b> Magnetic door stopper Дополнительно использован магнит блокирующий двери. Magnetischer Türstopper
	<b>A-80001-00</b>	szt. pcs шт. Stück	<b>6</b>	<b>001 002 003 004</b>	<b>Odbojniki do drzwi samoprzylepne.</b> Metalowa powierzchnia galwanizowana. Zabezpiecza przed obiciem ścian, klejony do podłoża. <b>Self-adhesive door bumpers.</b> Galvanized metal surface, prevents wall damage, screwed to the floor surface. <b>Отбойники дверей самоклеющиеся.</b> Металлическая гальванизованная поверхность предохраняют стены от обитания, прикручиваются к полу. <b>Selbstklebende Türstopper.</b> Verzinkte Metalloberfläche, verhindert Schäden an Wänden und kann mit dem Untergrund verschraubt werden.



**001**  
srebrny  
silver  
серебряный  
Silber



**002**  
srebrny mat  
silver mat  
серебро мат.  
Silber matt



**003**  
złoty  
gold  
золотой  
Gold



**004**  
antyk  
antique  
античный  
Antike











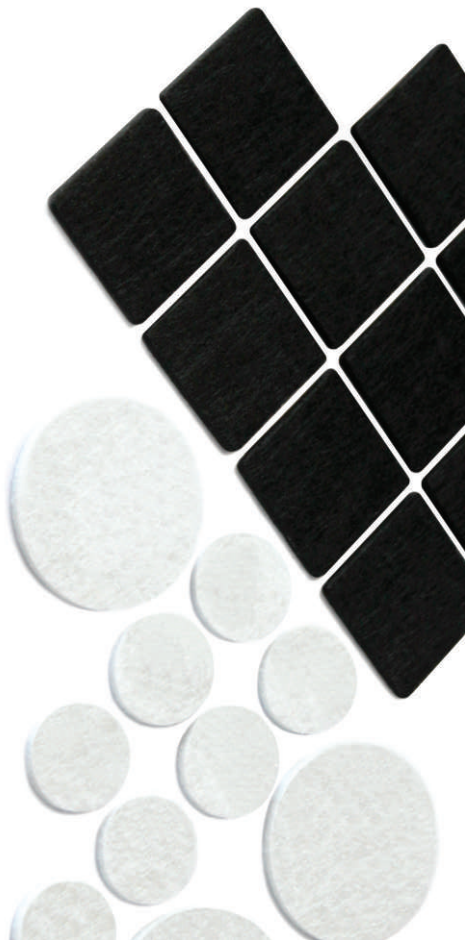























**020**  
stal nierdzewna  
stainless steel  
нержавеющий  
Edelstahl

# akcesoria

Accessories  
Принадлежности  
Zubehör

**aspro**



	rozmiar size размер Größe	ilość w opak. units / package кол. в упак. Stück / VE	nr artykułu article number артикул № Artikelnummer	j.m. unit e.и. Einheit	ilość w opak. units / package кол. в упак. Stück / VE	kolor colour цвет Farbe	uwagi comments применения Kommentare
	ø 20	( x 20 )	<b>A-40001-01-020</b>		<b>20</b>		
	ø 28	( x 12 )	<b>A-40001-02-012</b>	kpl. set компл. Set	<b>20</b>		
	20 x 20 mm	( x 20 )	<b>A-40001-03-020</b>		<b>20</b>		
	28 x 28 mm	( x 12 )	<b>A-40001-04-012</b>		<b>20</b>		
	120 x 100 mm	( x 1 )	<b>A-40001-05-001</b>	szt. pcs шт. Stück	<b>20</b>		
	44 x 20 mm	( x 10 )	<b>A-40001-06-010</b>		<b>20</b>		
	ø 20	( x 8 )	<b>A-40001-07-XXX</b>		<b>20</b>	biały white белый Weiß	Podkładki filcowe self-adhesive felts pads Подкладки войлочные самоклеющиеся. Selbstklebende Filzgleiter
	ø 38	( x 4 )					
	ø 10	( x 10 )	<b>A-40001-08-XXX</b>		<b>20</b>		
	ø 70	( x 4 )	<b>A-40001-09-XXX</b>	kpl. set компл. Set	<b>12</b>		
	150 x 115 mm	( x 1 )	<b>A-40001-10-038</b>		<b>10</b>		
	150 x 13 mm	( x 4 )					
	ø 18	( x 10 )					
	ø 23	( x 16 )					
	ø 35	( x 7 )					
	210 x 297 mm	( x 1 )	<b>A-40001-15-000</b>	szt. pcs шт. Stück	<b>1</b>		
	ø 20	( x 20 )	<b>A-40002-01-020</b>		<b>20</b>		
	ø 28	( x 12 )	<b>A-40002-02-012</b>	kpl. set компл. Set	<b>20</b>		
	20 x 20 mm	( x 20 )	<b>A-40002-03-020</b>		<b>20</b>		
	28 x 28 mm	( x 12 )	<b>A-40002-04-012</b>		<b>20</b>		
	120 x 100 mm	( x 1 )	<b>A-40002-05-001</b>	szt. pcs шт. Stück	<b>20</b>		
	44 x 20 mm	( x 10 )	<b>A-40002-06-010</b>		<b>20</b>		
	ø 20	( x 8 )	<b>A-40002-07-XXX</b>		<b>20</b>	czarny black черный Schwarz	Podkładki filcowe self-adhesive felts pads Подкладки войлочные самоклеющиеся. Selbstklebende Filzgleiter
	ø 38	( x 4 )					
	ø 10	( x 10 )	<b>A-40002-08-XXX</b>		<b>20</b>		
	ø 70	( x 4 )	<b>A-40002-09-XXX</b>	kpl. set компл. Set	<b>12</b>		
	150 x 115 mm	( x 1 )	<b>A-40002-10-038</b>		<b>10</b>		
	150 x 13 mm	( x 4 )					
	ø 18	( x 10 )					
	ø 23	( x 16 )					
	ø 35	( x 7 )					
	210 x 297 mm	( x 1 )	<b>A-40002-15-000</b>	szt. pcs шт. Stück	<b>1</b>		



# akcesoria

aspro®

Accessories  
Принадлежности  
Zubehör

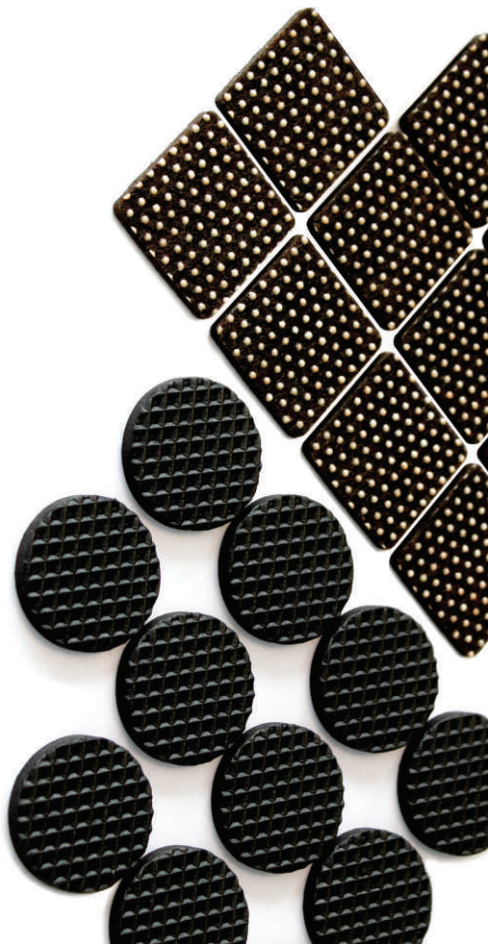









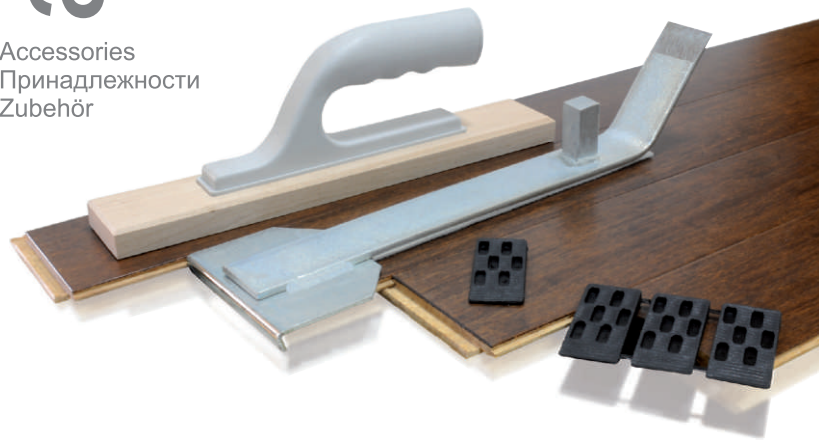

	rozmiar size размер Größe	ilość w opak. units / package кол. в упак. Stück / VE	nr artykułu article number артикул № Artikelnummer	j.m. unit e.i. Einheit	ilość w opak. units / package кол. в упак. Stück / VE	kolor colour цвет Farbe	uwagi comments применения Kommentare	
	ø 28	(x 12)	<b>A-40004-02-001</b>	kpl. set	<b>20</b>	brąz brown коричневая braun	<b>Podkładki filcowe samoprzylepne.</b>  Self-adhesive felts pads	
	28 x 28 mm	(x 12)	<b>A-40004-04-001</b>	kompl. Set	<b>20</b>			
	120 x 100 mm	(x 1)	<b>A-40004-05-001</b>	szt. pcs шт. Stück	<b>20</b>			
	150 x 115 mm	(x 1)	<b>A-40006-10-038</b>	kpl. set kompl. Set	<b>10</b>	piaskowy sand насок Sand	Подкладки войлочные самоклеющиеся.  Selbstklebende Filzgleiter	
	ø 18	(x 4)						
	ø 23	(x 16)						
	ø 35	(x 7)						
	210 x 297 mm	(x 1)						<b>A-40006-15-000</b>
	ø 28	(x 12)	<b>A-40003-03-XXX</b>	kpl. set	<b>20</b>	korek cork пробка Kork	<b>Podkładki korkowe samoprzylepne.</b>  Self-adhesive felts pads	
	28 x 28 mm	(x 12)	<b>A-40003-02-XXX</b>	kompl. Set	<b>20</b>			
	120 x 100 mm	(x 1)	<b>A-40003-01-XXX</b>	szt. pcs шт. Stück	<b>20</b>			
	150 x 115 mm	(x 1)	<b>A-40003-10-038</b>	kpl. set kompl. Set	<b>10</b>		Подкладки из натуральной пробки самоклеющиеся.  Selbstklebende Korkgleiter.	
	ø 18	(x 4)						
	ø 23	(x 16)						
	ø 35	(x 7)						
	210 x 297 mm	(x 1)						<b>A-40003-15-000</b>
	ø 28	(x 12)	<b>A-40005-02-001</b>	kpl. set kompl. Set	<b>20</b>	czarny black чёрная Schwarz	<b>Podkładki antyślizgowe samoprzylepne.</b>  Self-adhesive anti-slip pads	
	28 x 28 mm	(x 12)	<b>A-40005-04-001</b>					<b>20</b>
	150 x 115 mm	(x 1)	<b>A-40005-10-038</b>					<b>10</b>
	ø 18	(x 4)						
	ø 23	(x 16)						
ø 35	(x 7)							
	ø 28	(x 12)	<b>A-40005-02-002</b>	kpl. set	<b>20</b>	brąz brown коричневая braun	Подкладка противоскользкая самоклеющаяся.  Selbstklebende Filzgleiter	
	28 x 28 mm	(x 12)	<b>A-40005-04-002</b>	kompl. Set	<b>20</b>			
	210 x 297 mm	(x 1)	<b>A-40005-15-002</b>	szt. pcs шт. Stück	<b>1</b>			
	ø 9	(x 40)	<b>A-40007-10-040</b>	kpl. set	<b>24</b>	przezroczysty transparent прозрачный Transparent		
	ø 20	(x 12)	<b>A-40007-10-012</b>	kompl. Set	<b>24</b>			

# akcesoria

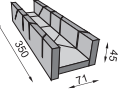
aspro®

Accessories  
Принадлежности  
Zubehör



	szt. pcs шт. Stück	nr artykułu article number артикул № Artikelnummer	j.m. unit e.i. Einheit	ilość w opak. units / package кол. в упак. Stück / VE	uwagi comments примечания Kommentare
	40 szt. 40 pcs 40 шт. 40 Stück	A-20001	kpl. set компл. Set	6	<b>Kliny montażowo-dylatacyjne.</b> Służą do dokładnego ustawienia i utrzymania szczeliny dylatacyjnej między układaną podłogą a ścianą. <b>Installation (distance) wedges.</b> Used for the precise adjustment and maintenance of the distance between the laid floor and the wall. <b>Шпонки для закрепления на расстоянии.</b> Используются для идеальной установки и удержания дилатационной щели между настиляемым полом и стеной. <b>Verlegekeile</b> Für präzises Arbeiten bei der Verlegung von Fußböden, damit der richtige Abstand zwischen Wand und Fußboden eingehalten wird.
<b>professional</b>   	40 szt. 40 pcs 40 шт. 40 Stück  1 szt. 1 pcs 1 шт. 1 Stück  1 szt. 1 pcs 1 шт. 1 Stück	A-CBE02	kpl. set компл. Set	6	<b>Zestaw montażowy - professional.</b> Łyżka dobijająca : 1, Kliny montażowo - dylatacyjne : 40 <b>Kłosek dobijający :</b> 1, Niezbędny do prawidłowego i łatwego montażu podłogi panelowej. <b>A set of fitting - professional.</b> Lyzka dobijająca : 1, 40 installation (distance) wedges, 1 tapping block <b>necessary for the proper and easy installation of a panel floor.</b> <b>Набор для настилки напольных панелей - professional.</b> рычаг : 1, шпонки для закрепления на расстоянии : 40 молоточный блок :1,необходим для правильной и несложной настилки, панельного пола. <b>Fußbodenmontage-Set</b> 1 Hebel, 40 Verlegekeile, 1 Schlagholz
	szt. pcs шт. Stück	A-CBB01	szt. pcs шт. Stück	6	<b>Skrzynka uciosowa.</b> Z progiem stabilizującym, cięcie pod kątem 45°, 90°. <b>Mitre box</b> 16 mm plywood. With a stabilizing sill, enables cutting at the angles of 45° and 90°. <b>Коническая втулка ДСП толщиной 16 мм.</b> Со стабилизирующим порогом, сечение под углом 45°, 90°. <b>Gehrungsleiste</b> Stabilisierung bei Schnitten von 45° und 90° Grad
  	40 szt. 40 pcs 40 шт. 40 Stück  1 szt. 1 pcs 1 шт. 1 Stück  1 szt. 1 pcs 1 шт. 1 Stück	A-90001	kpl. set компл. Set	6	<b>Zestaw do układania paneli podłogowych.</b> Łyżka dobijająca : 1, kliny montażowo - dylatacyjne : 40, <b>Kłosek dobijający :</b> 1, niezbędny do prawidłowego i łatwego montażu podłogi panelowej. <b>Flooring panel installation kit.</b> 1 lever, 40 installation (distance) wedges, 1 tapping block, <b>necessary for the proper and easy installation of a panel floor.</b> <b>Комплект для настилки напольных панелей.</b> рычаг :1, шпонки для закрепления на расстоянии : 40 молоточный блок :1, Необходим для правильной и несложной настилки панельного пола. <b>Fußbodenmontage-Set</b> 1 Hebel, 40 Verlegekeile, 1 Schlagholz
	24 szt. 24 pcs 24 шт. 24 Stück	A-BFC01	kpl. set компл. Set	8	<b>Kolki montażowe</b> Mounting dowels & screws Монтажные штифты Montagedübel
	24 szt. 24 pcs 24 шт. 24 Stück	A-BFC02	kpl. set компл. Set	8	









# akcesoria

**aspro®**

Accessories  
Принадлежности  
Zubehör



	dl. (cm) length (cm) длина (см) Länge (cm)	szerokość width (cm) ширина (см) Breite (cm)	nr artykułu article number артикул № Artikelnummer	j.m. unit е.и. Einheit	ilość w opak. units / package кол. в упак. Stück / VE	kolor colour цвет Farbe	uwagi comments примечания Kommentare
	1000	5	A-70002-00-001	szt. pcs шт. Stück	10	001	
	1000	5	A-70002-00-002	szt. pcs шт. Stück	10	002	<p><b>Taśma przeciwpślizgowa samoprzylepna.</b> Wykonana z materiału trudnościścieralnego. Zastosowanie na śliskie podłogi, schody, na platformy ciężarówek, odporna na wodę, oleje, smary, promienie słoneczne. <b>Self-adhesive anti-slip tapes.</b> Made of abrasion-resisting material, used on slippery floors, stairs, lorry platforms; water, oil, grease and sunlight resistant. <b>Лента противоскользящая самоклеющаяся.</b> Изготовлена из трудностриаемого материала, клеится на скользкие полы, ступеньки, на платформы грузовиков, устойчивая к воздействию воды, масел, смазок, солнечных лучей. <b>Selbstklebendes Anti-Rutsch Band</b> Abrieb- und Widerstandsfähiges Material. Findet Verwendung bei rutschigen Böden, Treppen, LKW Plattformen.</p>
	1000	5	A-70002-00-003	szt. pcs шт. Stück	12	003	
	1000	5	A-70002-00-005	szt. pcs шт. Stück	12	005	
	500	2,5	A-70003-00-001	szt. pcs шт. Stück	10	001	
	500	2,5	A-70003-00-002	szt. pcs шт. Stück	10	002	
	500	2,5	A-70003-00-004	szt. pcs шт. Stück	10	004	



001  
przezroczysty  
transparent  
прозрачный  
transparent



002  
czarny  
black  
черный  
Schwarz



003  
żółty  
yellow  
желтый  
Gelb



004  
brązowy  
brown  
коричневый  
Braun



005  
żółto - czarny  
yellow - black  
желтый - черный  
Gelb - Schwarz

# akcesoria **aspro**

Accessories  
Принадлежности  
Zubehör

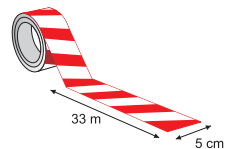
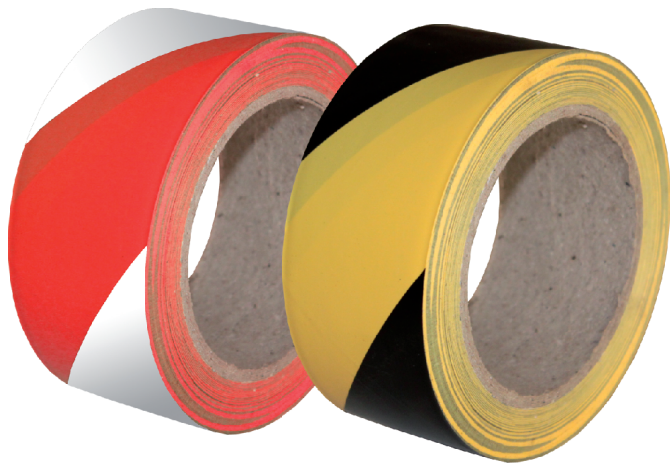

**A-70004-XX-001**

szt.  
pcs  
шт.  
Stück

**1**

biało - czerwona  
white - red  
белый - красный  
weiß - rot

**Taśma ostrzegawcza samoprzylepna**  
Self-adhesive warning tape  
Предупреждение клейкая лента  
Warnband Klebstoff



**A-70004-XX-002**

szt.  
pcs  
шт.  
Stück

**1**

żółto - czarna  
yellow - black  
желтый - черный  
gelb - schwarz

**Taśma ostrzegawcza samoprzylepna**  
Self-adhesive warning tape  
Предупреждение клейкая лента  
Warnband Klebstoff

nr artykułu  
article number  
артикул №  
Artikelnummer

j.m.  
unit  
е.и.  
Einheit

ilość w opak.  
units / package  
кол. в упак.  
Stück / VE

kolor  
colour  
цвет  
Farbe

uwagi  
comments  
примечания  
Kommentare

# mozaiki

kwarcowe



Glass mosaic  
Стекло́нная мозаика  
Glasmosaik

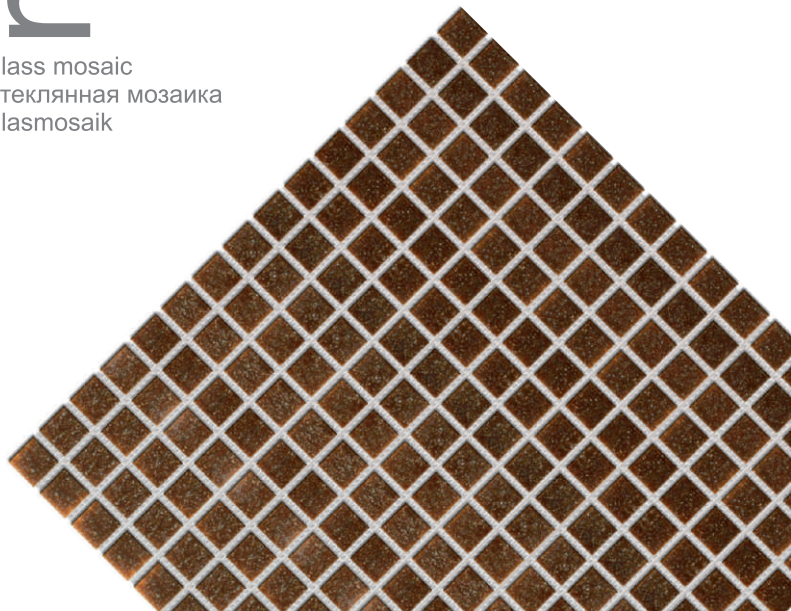

rozmiar  
size  
размер  
Größe

nr artykułu  
article number  
артикул №  
Artikelnummer

j.m.  
unit  
e.и.  
Einheit

ilość w opak.  
units / package  
кол. в ут.п.  
Stück / VE

nr koloru  
colour number  
цвет №  
Farbnummer



300 x 300 x 4  
■ 20 x 20

A-MKO04

szt.  
pcs  
шт.  
Stück

20

002, 004, 007, 008,  
010, 012, 014, 015,  
020

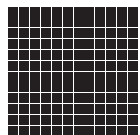

325 x 325 x 4  
■ 25 x 25

A-MKO04

szt.  
pcs  
шт.  
Stück

20

024



Katalog stanowi informację handlową  
i nie może być uznawany za ofertę w rozumieniu  
art. 66 ust. 1 Kodeksu Cywilnego.  
Stanowi on jedynie zaproszenie  
do rokowań w rozumieniu  
art. 71 Kodeksu Cywilnego.

Rozmiary i zdjęcia produktów  
mogą odbiegać od rzeczywistości.  
Producent zastrzega sobie prawo  
do wprowadzenia zmian.

Sizes and photos of products can differ  
from the real products.  
Manufacturer reserve the right  
to make amendments.

**GPS** Global Positioning System  
N 50°48'24,50"  
E 20°32'21,50"

**26-052 Nowiny k. Kielc**  
**ul.Przemysłowa 48, Poland**  
**tel./fax: +48 41 34 456 59**  
**[www.midas.pl](http://www.midas.pl), e-mail:[office@midas.pl](mailto:office@midas.pl)**